

A STUDY ON NEURO FUZZY ALGORITHM IMPLEMENTATION ON BCI-UAV CONTROL SYSTEMS

Timothy Scott Chu ^{1,2}, Alvin Chua ¹, and Emanuele Lindo Secco ²

¹ Mechanical Engineering Department, Gokongwei College of Engineering, De La Salle University, Manila, Philippines, Tel: +6325244611 loc. 200, e-mail: timothy.chu@dlsu.edu.ph, alvin.chua@dlsu.edu.ph

² Robotics Laboratory, School of Mathematics, Computer Science & Engineering, Liverpool Hope University, UK, e-mail: seccoe@hope.ac.uk

Received Date: *for Editorial Office's use only*

Abstract

Brain-Computer Interface (BCI) machines are capable of obtaining brain activities by conducting Electroencephalogram tests. Developments on both BCI and Machine Learning allowed various researchers to develop and study various BCI control systems, mainly varying with the algorithm implementation.

This research presents a performance analysis of the *Adaptive Neuro-Fuzzy Inference System* (ANFIS) for BCI control systems for drone maneuverability. Eye gestures were used to generate the EEG data that were captured using the Emotiv INSIGHT Neuroheadset. The obtained data were transferred to the computing hardware using IEEE 802.15 wireless communication protocol (i.e. Bluetooth connectivity); the data are processed using the 5th order Butterworth Band-Pass filtering and heuristic filtering. The filtered dataset is then fed to the ANFIS and a *Support Vector Machine* (SVM) algorithm, the latter serving as the basis, for training and quadcopter control implementation.

Three flight tests were done, hover test, flight command test, and the flight control test to obtain the performance of the control system in terms of accuracy. Results from the initial two tests showed that the ANFIS performed comparably with the SVM, and even about 2% better with an accuracy of 79%. The final test showed that the BCI control system had a maximum variance of 4% compared to the handheld remote controller, where the latter served as the basis. It was found that between Machine Learning algorithms, ANFIS is as capable as the SVM for BCI control systems. Further developments may focus on employing time-series EEG preprocessing techniques.

Keywords: ANFIS, Brain Computer Interface, Quadcopter, SVM, Unmanned Aerial Vehicle, UAV

Introduction

Brain-Computer Interface (BCI) is a category of machines that performs *ElectroEncephaloGram* (EEG) analysis to extract information on the human brain's activity. Developments in the said technology have made the ideas from old science-fiction movies, specifically controlling objects with one's mind, a reality today. Paired also with developments in *Artificial Intelligence* (A.I.) has made the idea of controlling objects with one's mind more accessible to most people, including researchers in the field of Robotics.

BCI-Robotic implementation is a growing field where numerous prototypes of different implementations were developed by various researchers. In the research [1], the proponents made a BCI-Robotic Arm prototype and controlled the robotic arm by moving it left and right. The researchers used raw EEG data obtained by the *Emotiv EPOC (EPOC) Neuroheadset* and the *Linear Discriminant Analysis (LDA)* as their classifying algorithm. The algorithm was tasked to classify the incoming EEG signal data into three categories, neutral, left, and right, which correspondingly moved the robotic arm. The study [2] took a different approach for the same implementation by using the concept of *Steady-State Evoked Potential (SSVEP)* as their EEG generation technique. The concept requires visual stimulations often in the form of flickering lights. The researchers used an LED panel with four colors, red, blue, green, and white; all flickering at different frequencies as their visual stimulus. The subject simply observes a single LED color and a distinct brainwave activity was generated for each color. They have also employed a combination of Power Spectral Density (PSD) as the feature extractor and Classification Tree Method, to classify the obtained data. This enabled the robotic arm to move around according to the defined action-color configuration.

Researchers in [3] have implemented the BCI control system in maneuvering a quadcopter by also employing the SSVEP concept, but instead of following the techniques in [2], the researchers employed a combination of *Butterworth Band-Pass filter* to preprocess the obtained EEG data and *Fast Fourier Transform (FFT) Spectral Analysis* as the feature extractor and classifier. The study was able to control the quadcopter to execute the following commands: take-off, land, pitch forward, yaw clockwise.

Variations in research implementations were observed to be mainly on the preprocessing techniques and the Machine Learning algorithm employed for classification. Neural Networks, particularly Convolutional Neural Network (CNN) and Artificial Neural Network (ANN), were found to be commonly used for EEG data classification as they can provide high accuracy results; however, the mentioned algorithms would take up much computational time when exposed with large datasets [4]. Another very popular algorithm that is employed is the Support Vector Machines (SVM). Its efficiency and effectiveness in generating accurate classifications made the algorithm popular for BCI implementations. However, inexperienced users would experience difficulty in developing an effective kernel for a particular use-case [5]. Additionally, the SVM algorithm would experience a drop in performance when managing large datasets as well. The study [6] highlighted that similar gestures generate similar EEG signals. Implying that the generated signals possessed a degree of overlapping or possessed similar features between classifications. The challenge, therefore, is to develop or utilize an algorithm that provides a balanced trade-off between accuracy and computational time, as well as to address the concern of similar EEG data features.

Individuals who possess physical limitations may benefit from this system as it allows them to perform important day-to-day tasks or physically intensive tasks. Providing them opportunities to have a relatively better lifestyle. A potential application, explored by one of the studies, is a BCI-Control system for unmanned vehicle maneuvering, particularly quadcopters. This control system may replace traditional hand-held remote controllers, which may offer a more immersive experience with similar difficulty in control. Quadcopters offer several benefits,

specifically in rescue operations, as it is capable of scanning dangerous environments, obtaining information which rescuers can use to aid in their operations [7]. This motivated the researcher to develop a BCI-Control system for quadcopter application.

Generally, BCI control systems possess two main concerns, generating the EEG signal and processing the produced input signal. BCI-quadcopter control systems often rely on external stimuli, such as flashing lights, prompting the brain to produce usable EEG signals. This form of EEG signal generation would not be appropriate for individuals with a seizure history. As highlighted in the study [6], generated EEG signals would exhibit similar or overlapping characteristics for similar gestures. Thus, utilizing an appropriate algorithm would play a significant role in the implementation of the BCI-quadcopter control system.

To address the raised challenges, this paper employs the Butterworth Band-pass filter to preprocess the obtained EEG data and the *Adaptive Neuro-Fuzzy Inference System (ANFIS)* as the classifier, to maneuver a quadcopter, or *Unmanned Aerial Vehicle (UAV)* while using face gestures to generate EEG signals. One of the critical concerns of processing EEG data is its similar characteristics across similar actions such as the closing of the left eye and the closing of the right eye. In the study [8] that compares the performance of SVM and ANFIS algorithm in EEG data classification, it was found that the ANFIS algorithm was able to perform comparably or better than the SVM with an accuracy of 90.13% while requiring a relatively small dataset, unlike the CNN and ANN algorithms. This study presents a control system, utilizing the mentioned technique and algorithm, for BCI-UAV implementation; and, provides a performance analysis of the whole system by conducting several test flights. Accuracy is the main metric used for the performance analysis, however, two contexts for accuracy are provided in this study. These are accuracy in terms of the number of correct executions, and accuracy in terms of flight distance. The former shows how well the algorithm performs in real-time operation, while the latter shows how well the UAV traverses the desired distance while using the proposed control system. The study also provides performance comparisons to gain perspective on the performance of the ANFIS algorithm. The primary objective for this study is to evaluate the viability of an ANFIS based control system for BCI-UAV implementation, which is the prerequisite for the study's general goal of developing an intuitive and wearable controller for piloting the quadcopter; this implementation would possess a variety of potential applications in rescue/emergency operations, commercial operations, and leisure.

Methodology

Theoretical Approach

Adaptive Neuro-Fuzzy Inference System

The Adaptive Neuro-Fuzzy Inference System (ANFIS) was developed by Jyh-Shing Roger Jang in 1993; and, it combines the *Fuzzy Inference System* with the *Adaptive Network*, the latter which is being employed by Neural Networks, making this one type of *Fuzzy Neural Network* [4].

Figure 1. represents a general architecture of the Fuzzy Inference System. It is comprised of four main parts, *Fuzzification*, *Defuzzification*, *the Knowledge Base*, and *the Decision-Making Unit*.

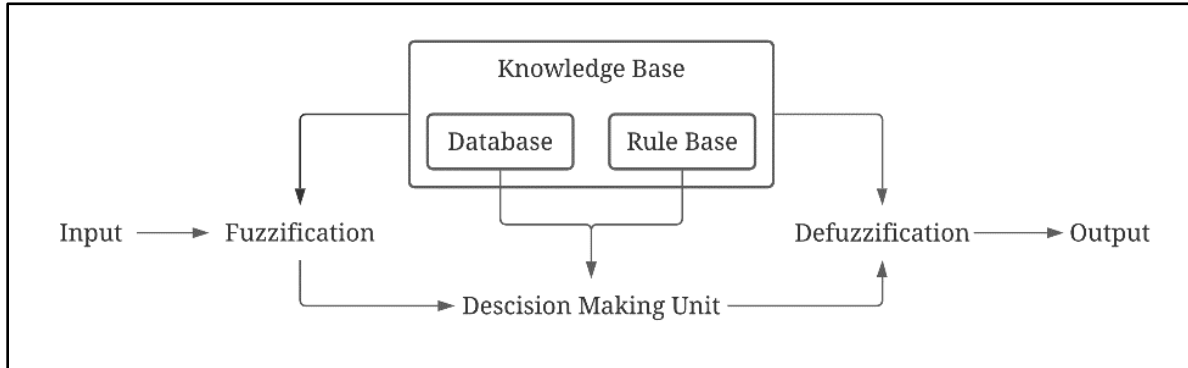

Figure 1. The adopted Fuzzy Inference System (FIS), adapted from [4].

The Fuzzification process simply translates the input crisp values to fuzzified input values, measuring the degree of belongingness in a particular classification, with the use of *Membership Functions*. There are several Membership Functions available, however, for this research, the *Gaussian Membership Function* is employed, shown in equation 1. Information such as the Membership Function is stored in the Database, under the Knowledge Base.

$$K(x_i, x_j) = e^{-\frac{\|x_i - x_j\|^2}{2\sigma^2}} \quad (1)$$

The reverse of this process is called Defuzzification, where, using the same Membership Function, the output fuzzified values are translated back to crisp values. The Decision-Making Unit is where the fuzzified input values go through what is called Fuzzy Operators (e.g. Min and Max) and are then compared to specified criteria stored in the Rule Base. The ANFIS employs the Type 3 -Takagi-Sugeno Fuzzy If-Then rules.

The Adaptive Network enables the “learning” in the training process of the algorithm. This allows the algorithm to adapt to errors by obtaining accuracy and loss rates and adjusting its parameters for each iteration until it satisfies a specified stopping criterion. The ANFIS employs a hybrid learning process. This suggests that the algorithm uses a function, often the Least Squares Estimate, for its forward pass; and, another function, often the Gradient Descent, for its backward pass in the learning process. This is presented in Table 1.

Table 1. Hybrid Learning Process for ANFIS

	Forward Pass	Backward Pass
Premise Parameters	Fixed	Gradient Descent
Consequent Parameters	Least Squares Estimate	Fixed
Signals	Node Outputs	Error Rates

Figure 2. shows a general architecture of the ANFIS algorithm. It is composed of 5 layers, where fuzzification occurs on the first layer.

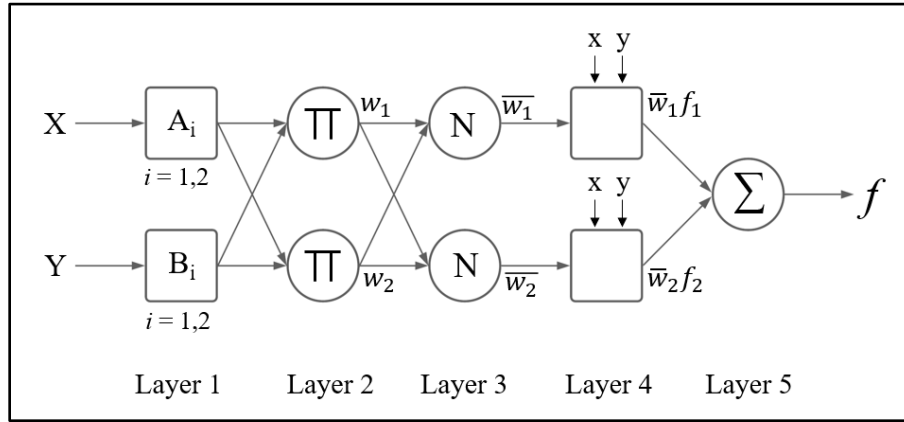

Figure 2. ANFIS Architecture, 2 Inputs and 1 Output, adapted from [4]

Layers 2 and 3 are where parameters and normalized parameters are calculated. In application, it is common to merge both layers into one function. Equations 2 and 3 show how weights are calculated on these layers.

$$w_i = \mu_{A_i}(x) \times \mu_{B_i}(x), i = 1,2 \quad (2)$$

$$\bar{w}_i = \frac{w_i}{w_1 + w_2} \quad (3)$$

On the next layer, layer 4, consequent parameters are computed by getting the product between the normalized weight and the Rule Base function, f , shown in equations 4.

$$O_i^4 = \bar{w}_i f_i = \bar{w}_i (p_i x + q_i y + r_i) \quad (4)$$

The variables p_i , q_i , and r_i represent the design parameters of the system. Finally, outputs from the fourth layer are collated, calculated, and defuzzified to give a single output, shown in equation 5.

$$O_1^5 = \text{overall output} = \sum_i \bar{w}_i f_i = \frac{\sum_i w_i f_i}{\sum_i w_i} \quad (5)$$

The provided architecture assumes a system with two inputs and a single output with 2 classifications, thus it follows two rules presented in equations 6 and 7.

$$\text{Rule 1: If } (x_1 \text{ is in } A_1) \text{ and } (x_2 \text{ is in } B_1), \text{ then } (\hat{y} = p_1x_1 + q_1x_2 + r_1) \quad (6)$$

$$\text{Rule 2: If } (x_1 \text{ is in } A_2) \text{ and } (x_2 \text{ is in } B_2), \text{ then } (\hat{y} = p_2x_1 + q_2x_2 + r_2) \quad (7)$$

The whole system can be expanded accordingly to fit the particular use-case of the researcher. This research expanded the algorithm to accept 10 input values, provide a single output, and possessing five rules.

Brain Rhythms

Brain activities are often represented in the form of brainwaves, with five brain rhythms mainly varying in frequencies [9]. The first wave is the Delta wave with a frequency range of 4 Hz or below, followed by Theta waves possessing a frequency range of 4 Hz to 7 Hz. Alpha and Beta waves follow after, with frequency ranges from 7 Hz to 13 Hz and 13 Hz to 30 Hz respectively. Finally, the Gamma waves are observed on frequencies 30 Hz or above.

Each wave classification effectively describes a particular action; for example, lower frequencies, such as Delta and Theta, effectively show and describe sleep states and patterns, while the Alpha waves are often associated with a conscious and calm state. Higher frequencies such as Beta and Gamma often give out significant information when an individual is alert or physically moving. It is also worth noting that motor imagery is associated with higher brain wave frequency

System Architecture

The methodology sequence used in this research is presented in Figure 5. The system began with EEG data generation which was then acquired by the Emotiv INSIGHT Neuroheadset. The obtained signals were sent to OpenViBE software for processing; then, the processed data is fed to the algorithms to maneuver the quadcopter through the use of the Python Box function.

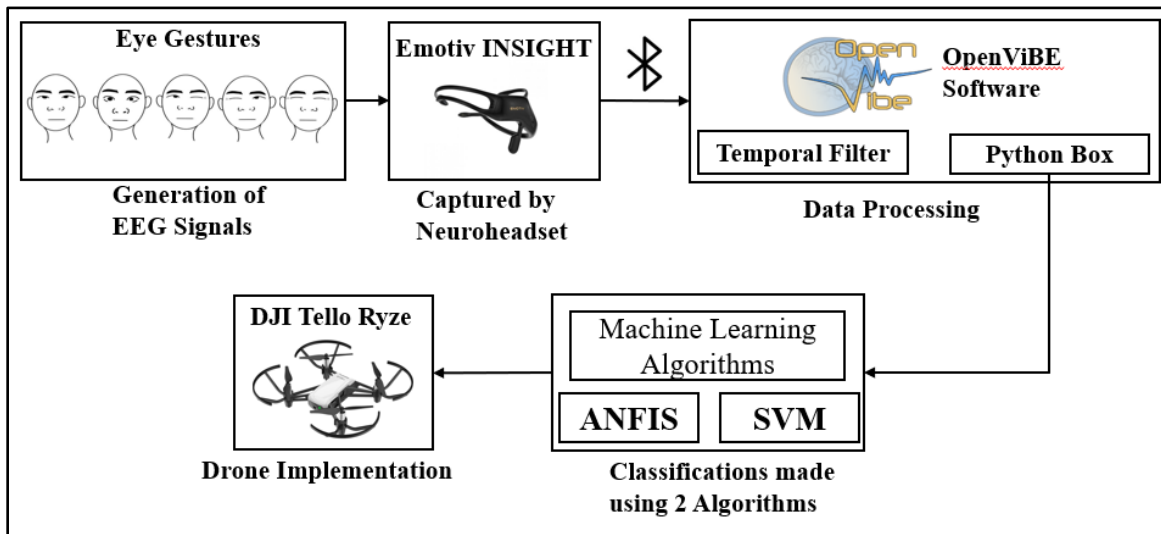

Figure 3. The overall architecture of the proposed system.

Generation of EEG Signals

Face gestures, specifically Eye gestures, were used to generate EEG signals for this control system. This idea was presented in the study [10]. The mentioned study was able to obtain an accuracy rate of 80% for the utilization of left and right wink gestures for the opening and closing of the robotic gripper. This research further expands the concept by employing 5 eye gestures, presented in Figure 6.

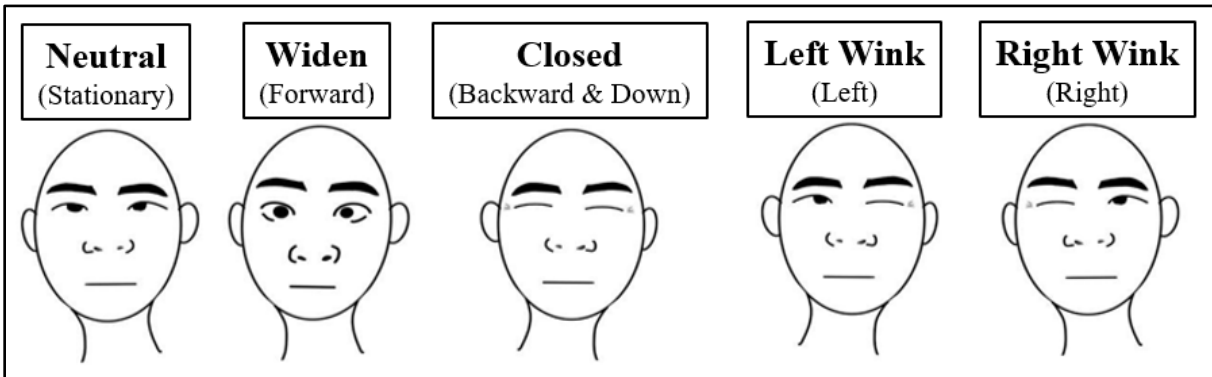

Figure 4. Overview of the facial expression (i.e., the Eye Gestures) for EEG Signal discrimination.

An electrical resonance was generated along the frontal lobe of the brain when these gestures were performed, particularly recognizable on the Beta and Gamma waves, 13 Hz to 43 Hz. This phenomenon was observed since the brain would generate electrical signals along the frontal lobe, responsible for motor functions of the body, to conduct facial movements. These signals were captured by the Emotiv INSIGHT Neuroheadset and translated into numerical values measured in millivolts (mV).

The Emotiv INSIGHT Neuroheadset

The Emotiv INSIGHT, shown in Figure 7 (a), is a non-invasive BCI Machine equipped with five semi-dry polymer sensors that are positioned following the international 10-20 system for electrode placements, shown in Figure 7 (b). The neuroheadset was set to obtain two samples per epoch of brain activity, consequently obtaining two sets of reading at 7.8 ms interval across the 5 sensors for 1 epoch. The obtained signal was communicated to OpenViBE software with the use of a Bluetooth Dongle connected to the computing hardware.

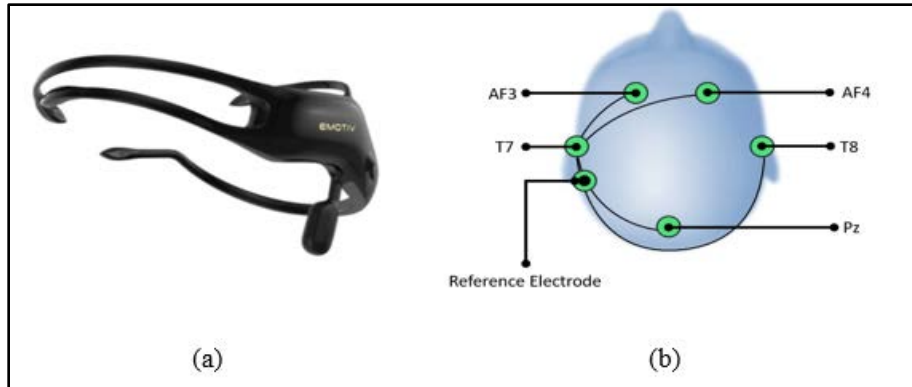

Figure 5. (a) Emotiv INSIGHT Neuroheadset, adapted from [8]; (b) Sensor Layout for Emotiv INSIGHT

OpenViBE

The *Open Virtual Brain Environment* (OpenViBE) is an open-sourced software that enabled researchers to develop and test their own BCI machines. The software is capable of streaming and processing EEG data in real-time. It has multiple built-in functions called boxes which users can utilize.

Four main box features were used in this research, first was the Acquisition Client Box, where the OpenViBE software interfaced and collected the data obtained by the Emotiv INSIGHT. The second was the Temporal Filter Box, where researchers applied a *Butterworth Band-Pass Filter* of the *5th Order* with cut-off frequencies of *13 Hz* and *43 Hz* as the lower and higher cut-off boundaries. The logic behind the selection of cut-off frequencies was mainly due to brainwave activities being evident along with the Beta and Gamma waves for motor functions. The use of Butterworth Band-Pass filter was found to be effective filtering tools especially in EEG data processing [8,11]. The third was the CSV File Writer box, where the filtered data was exported into a .csv file for further processing. On top of the Butterworth Band-Pass filter, heuristic filtering was also applied. This was achieved by locating the minima and maxima of the eye gesture event, serving as the key features of a particular eye gesture. The filtered dataset was used to train the machine learning algorithms which were programmed to maneuver the drone according to the face gesture. The machine learning algorithms were coded using python programming, which was accessible with the fourth box from OpenViBE called the Python Scripting Box.

Testing set up and flights

Using the DJI Tello Ryze quadcopter (Figure 8) a total of three test flights were performed; namely the hover test, the flight command test, and the flight control test, were conducted in this study. The hover test tasked the quadcopter to take-off and land when corresponding gestures were executed, neutral and smile. This particular test aimed to offer a preview of how well each algorithm performs on two classifications. This test was evaluated by taking note of the number of successful take-offs and landing sequences against the total number of trials.



Figure 6. DJI Tello Ryze Quadcopter

The objective of the flight command test was to have the quadcopter execute the roll and pitch commands according to the eye gesture. This test aimed to evaluate the algorithm's performance on more classifications that offers a close representation of a complete system. A confusion matrix was used to evaluate the results of this experiment.

Finally, the flight control test required the user to control the quadcopter similar to a traditional handheld remote controller. Instead of comparing the ANFIS to the SVM, the prior algorithm was compared to a handheld remote controller to offer a comparison between the proposed method and the current implementation. The researcher recorded and plotted the flight path of the quadcopter for both control systems and compared how well the control systems maneuvered the quadcopter along with the experimental setup. Figure 9 shows the experimental setup for the Flight Control Test, the red X represents visual markers as an indicator for the researcher to move to the next marker.

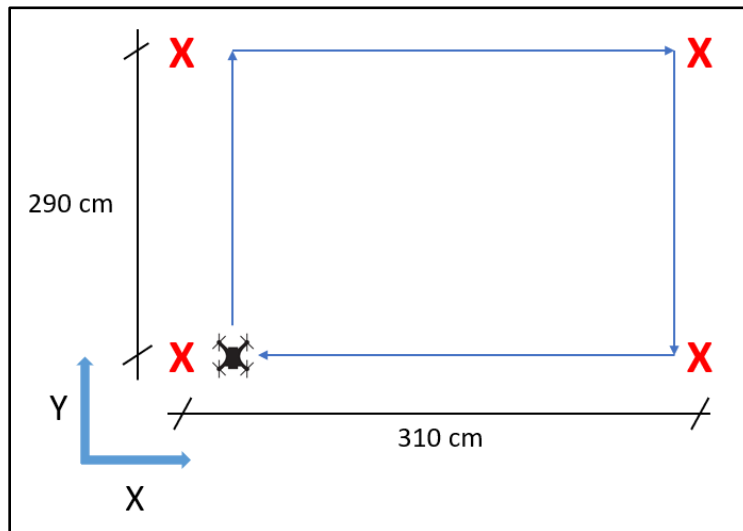

Figure 7. Flight Control Test Experimental Setup

Results and Discussion

Hover Test

Figure 10 showed the manner in how the experiment was conducted. Both algorithms were tasked to classify between 2 categories, neutral and smile, and maneuver the quadcopter to land and take-off respectively. This sequence was repeated five times to complete a run.

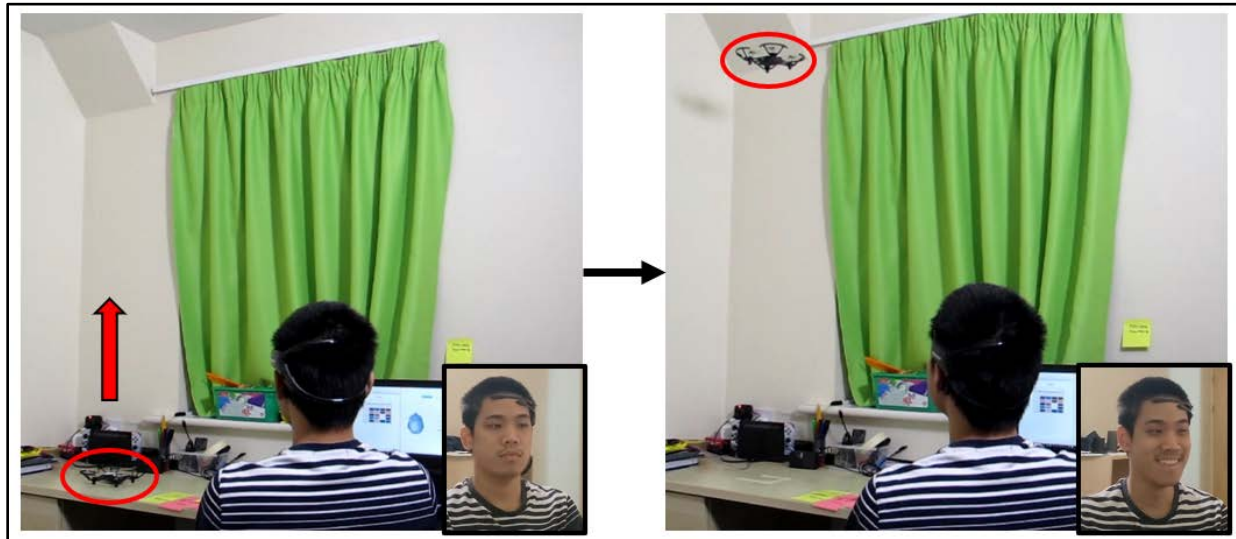

Figure 8. Hover Test

Table 2 shows the number of successful attempts for each run.

Table 2. Results of Hover Test

Hover Test	SVM Successful Attempts	ANFIS Successful Attempts
Run 1	5 / 5	4 / 5
Run 2	3 / 5	3 / 5
Run 3	2 / 5	3 / 5
Total Correct	10 / 15	10 / 15

As observed from the results, the ANFIS algorithm had 10 out of 15 successful attempts, or 66.67%. The SVM algorithm, on the other hand, performed similarly with 10 successful attempts as well. The difference was found in the performance of both algorithms for each run; the SVM algorithm had a maximum of three errors while the ANFIS algorithm obtained a maximum of 2 errors based on this data. Results from this test presented an idea that the ANFIS is comparable to the SVM, however, the Flight Command Test would provide a more substantial performance analysis of the ANFIS algorithm.

Flight Command Test

In this experiment, the researcher expanded the number of classifications from two to five, corresponding to the eye gestures in the Figure 6. Each classification moves the drone a defined distance forward, left, right, and backward then land. Figure 11 offers a visualization of this experiment.



Figure 9. Flight Command Test

A total of 30 were performed and results are recorded in a confusion matrix where the ground truth and algorithm classification results are reported (Tables 3 and 4).

Table 3. Flight Command Test Results for SVM

Flight Test (SVM)	Neutral	Forward	Left	Right	Backward & Down	Total Correct
Neutral	26	2	1	1	0	26
Forward	3	24	1	2	0	24
Left	4	2	21	2	1	21
Right	5	2	0	22	1	22
Backward & Down	4	2	2	0	22	22
<i>Average Accuracy</i>	<i>88.67%</i>	<i>80.00%</i>	<i>70.00%</i>	<i>73.33%</i>	<i>73.33%</i>	<i>76.67%</i>

Table 4. Flight Command Test Results for ANFIS

Flight Test (ANFIS)	Neutral	Forward	Left	Right	Backward & Down	Total Correct
Neutral	25	1	2	1	1	25
Forward	3	25	1	1	0	25
Left	5	2	21	2	0	21
Right	3	2	0	25	0	25
Backward & Down	6	2	0	0	22	22
Average Accuracy	83.33%	83.33%	70.00%	83.33%	73.33%	78.67%

Results from both algorithms showed that ANFIS shyly performed better than the SVM, the former obtaining an accuracy rate of 78.67% while the latter obtained 76.67%, a difference of about 2%. The highest and lowest number of correct classifications for the SVM were 26 and 21 respectively.

The ANFIS algorithm on the other hand obtained 25 correct classifications as the highest count, and 21 as the lowest count. The researchers also noted that the ANFIS was able to predict 25 correct classifications across different categories, whereas the SVM was able to obtain 26 correct classifications once.

While this test showed that the ANFIS can be somehow more consistent in its classifications compared to the SVM, it should also be noted that both algorithms generated more than 20 correct predictions. This validated that for BCI implementation, the ANFIS algorithm can indeed perform comparably with the SVM algorithm.

It was also observed that most of the errors lie in the neutral classification. This was due to the nature of the pre-processing techniques employed in this study. Processing data as time series data may yield better performance for the implementation.

Flight Control Test

This experiment extended the previous test by controlling the quadcopter with the ANFIS implemented BCI-Control system as if it was a remote controller. Given that condition, the performance of the ANFIS algorithm was compared to the traditional handheld remote controller. Figure 12 offers a visualization of the quadcopter’s flight path comparing the theoretical, BCI-UAV Control, and Handheld Controller.

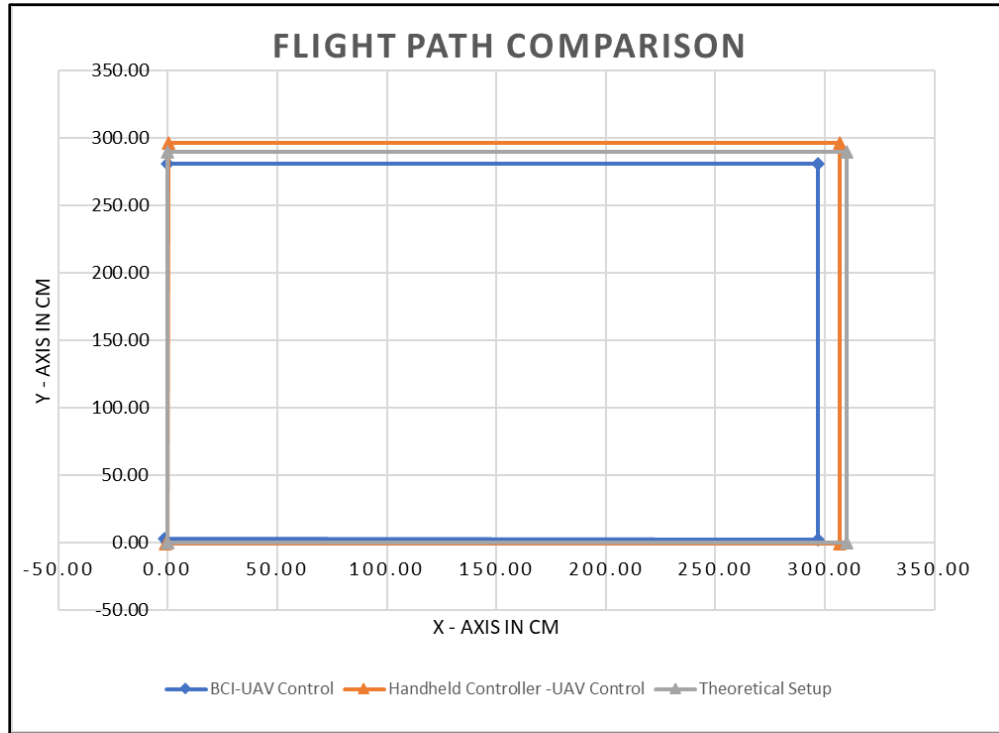

Figure 10. Flight Path Comparison

It was observed that the BCI-UAV Control fell short of the theoretical setup while the Handheld Control overshoot the targets set. Tables 5 more substantial information on how much the undershoot occurred on the BCI-UAV Control System.

Table 5. Flight Control Test Results – BCI-UAV Control System

Command	Theoretical Y (in cm)	Theoretical X (in cm)	BCI (Y_Pos) (in cm)	Var Y (in cm)	BCI (X_Pos) (in cm)	Var X (in cm)
Take off	0.00	0.00	0.00	0.00	0.00	0.00
Forward	290.00	0.00	280.68	9.32	0.02	0.02
Right	290.00	310.00	280.70	9.30	296.89	13.11
Backward	0.00	310.00	2.71	2.71	296.91	13.09
Left	0.00	0.00	2.73	2.73	-1.44	1.44
Average				4.81		5.53

In table 5, the average variance in the BCI-UAV control system was 4.81 cm along the Y-Axis and 5.53 cm along the X-Axis with a maximum variance of 13.11 cm along the X-Axis. Comparing values between the Theoretical conditions and BCI results, confirmed that the latter would usually fall short of meeting the target. Table 6 on the other hand, showed that the Handheld

control system obtained an average variance of 2.75 cm along the Y-Axis and 1.45 cm along the X-Axis. Comparing theoretical conditions and Handheld results shows that this control system goes beyond the set targets, unlike the BCI-UAV control system.

Table 6 offers more details to the overshoot in the Handheld-UAV Control System.

Table 6. Flight Control Test Results – Handheld-UAV Control System

Command	Theoretical Y (in cm)	Theoretical X (in cm)	Handheld (Y_Pos) (in cm)	Var Y (in cm)	Handheld (X_Pos) (in cm)	Var X (in cm)
Take off	0.00	0.00	0.00	0.00	0.00	0.00
Forward	290.00	0.00	296.11	6.11	0.23	0.23
Right	290.00	310.00	296.13	6.13	307.00	3.00
Backward	0.00	310.00	-0.76	0.76	307.02	2.98
Left	0.00	0.00	-0.74	0.74	-1.03	1.03
Average				2.75		1.45

Figure 13 presents a comparison of the distance traveled between BCI and Handheld control systems. The BCI control system traveled a distance 3-4% shorter than the Handheld control system with variances from 9.70 cm up to 18.91 cm, with the latter control system as the reference.

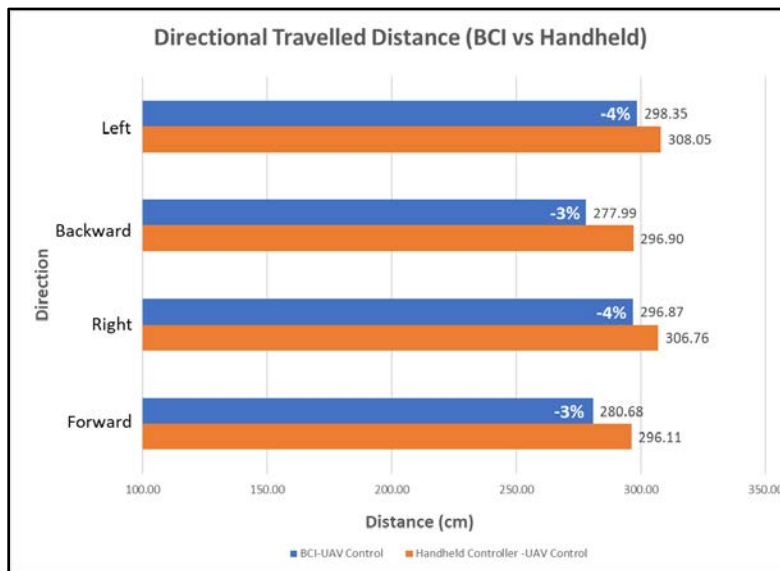

Figure 11. Directional Travelled Distance (BCI vs Handheld)

Generally, results from the BCI-UAV Control system lagged from the theoretical setup, while results from the Handheld Controller-UAV Control system exhibited a different behavior by

overshooting the set targets. Comparing both control systems, a maximum variance of 4% or 18.91 cm was observed. This is generally acceptable for single drone operation; however, this may not be acceptable for swarm implementations. Nonetheless, the BCI-UAV Control System exhibited satisfactory behavior in maneuvering the quadcopter along with the set target points, albeit falling short. This may be improved by employing different preprocessing techniques and a more efficient algorithm.

Conclusions

This research explored the viability of utilizing the ANFIS algorithm in BCI-Control implementations by maneuvering a quadcopter. Eye gestures were employed as the EEG signal generation technique and the Emotiv INSIGHT Neuroheadset was used to obtain and send the generated signals to the computing hardware through Bluetooth connectivity. The obtained data were processed using the Butterworth Band-Pass filter and Heuristic Filtering, and the preprocessed data were fed to the Machine Learning algorithms. A total of three experiments were conducted, the hover test, the flight command test, and the flight control test. In the first 2 experiments, the performance of ANFIS was compared to the SVM, a well-known algorithm for BCI implementations. Results from the first two experiments showed that the ANFIS performed comparably with the SVM; the hover test showed similar performance between both algorithms and the flight command test showed that ANFIS performed 2% better than the SVM. In the last experiment, the BCI-UAV Control system employing the ANFIS algorithm was compared to a traditional handheld remote controller in maneuvering a drone. Results showed a 3-4% variance between BCI-UAV Control and Handheld Remote Control, where the latter served as the reference.

The ANFIS algorithm was found to be capable and effective in BCI Control systems as it has performed comparably with the SVM. The algorithm was also able to perform comparably against a traditional method of maneuvering a quadcopter. However, most of the misclassifications as observed in the flight command tests were the neutral classification. This is mainly because the data was processed and utilized on a per-sample basis. This can be improved by processing the obtained EEG data further with time-series preprocessing techniques such as the *Fast Fourier Transform* (FFT). Nonetheless, the implemented BCI control system was still successful in maneuvering a quadcopter and the presented architecture may be used as a reference for other BCI-Robotic implementations.

Acknowledgments

This work was presented in dissertation form in fulfilment of the requirements for the MSc in Robotics Engineering and MS Mechanical Engineering for Timothy Chu under the supervision of E.L. Secco from the Robotics Laboratory, School of Mathematics, Computer Science and Engineering, Liverpool Hope University, UK and of Dr. Alvin Chua from the Mechanical Engineering Department, De La Salle University, PH.

References

- [1] D. Prince, M. Edmonds, A. Sutter, M. Cusumano, W. Lu and V. Asari, "Brain machine interface using Emotiv EPOC to control robai cyton robotic arm," *2015 National Aerospace and Electronics Conference (NAECON)*, Dayton, OH, pp. 263-266, 2015.
- [2] K. Holewa and A. Nawrocka, "Emotiv EPOC neuroheadset in brain – computer interface," *Proceedings of the 2014 15th International Carpathian Control Conference (ICCC)*, Velke Karlovice, pp. 149-152, 2014.
- [3] Chiuzbaian, J. Jakobsen and S. Puthusserypady, "Mind Controlled Drone: An Innovative Multiclass SSVEP based Brain Computer Interface," *2019 7th International Winter Conference on Brain-Computer Interface (BCI)*, Gangwon, Korea (South), pp. 1-5, 2019.
- [4] J. -. R. Jang, "ANFIS: adaptive-network-based fuzzy inference system," in *IEEE Transactions on Systems, Man, and Cybernetics*, vol. 23, no. 3, pp. 665-685, May/June 1993.
- [5] M. Tavakoli, C. Benussi, P. Alhais Lopes, L. Osorio and A. de Almeida, "Robust hand gesture recognition with a double channel surface EMG wearable armband and SVM classifier", *Biomedical Signal Processing and Control*, vol. 46, pp. 121- 130, 2018. Available: 10.1016/j.bspc.2018.07.010
- [6] S. Li and H. Feng, "EEG Signal Classification Method Based on Feature Priority Analysis and CNN," *2019 International Conference on Communications, Information System and Computer Engineering (CISCE)*, Haikou, China, pp. 403-406, 2019.
- [7] Y. Karaca et al., "The potential use of unmanned aircraft systems (drones) in mountain search and rescue operations," *The American Journal of Emergency Medicine*, vol. 36, no. 4, pp. 583-588, 2018. Available: 10.1016/j.ajem.2017.09.025.
- [8] T. S Chu, A.Y. Chua, E.L. Secco, "Performance Analysis of a Neuro Fuzzy Algorithm in Human Centered & Non-Invasive BCI," Paper presented at *6th International Congress on Information and Communication Technology (ICICT)*, in press, London, United Kingdom, February 2021.
- [9] EMOTIV. 2020. *The Introductory Guide To EEG (Electroencephalography) – EMOTIV*, [Online]. Available at: <<https://www.emotiv.com/eeg-guide/>> [Accessed 20 September 2020].
- [10] N. Zamora, D. S. Benítez and M. S. Navarro, "On the Use of the EMOTIV Cortex API to Control a Robotic Arm Using Raw EEG Signals Acquired from the EMOTIV Insight NeuroHeadset," *2019 IEEE CHILEAN Conference on 103 Electrical, Electronics Engineering, Information and Communication Technologies (CHILECON)*, Valparaiso, Chile, pp. 1-6, 2019.
- [11] Curone D., Bertolotti G., Cristiani A., Secco E. L., Magenes G., "A Real-Time and Self-Calibrating Algorithm Based on Tri-Axial Accelerometer signals for the Detection of Human Posture and Activity," *IEEE Trans on Information Technology in Biomedicine*, Vol. 14 (4), pp. 1098-1105, 2010.