Modified SIRD Model for COVID-19 Spread Prediction for Northern and Southern States of India

Sakshi Shringi · Harish Sharma · Pushpa Narayan
Rathie · Jagdish Chand Bansal · Atulya Nagar

the date of receipt and acceptance should be inserted later

Abstract The Severe Acute Respiratory Syndrome Coronavirus 2 (SARS-CoV-2) is the strain of coronavirus that causes coronavirus disease (COVID-19), the respiratory illness that resulted in COVID-19 pandemic in early December 2019. Due to lack of knowledge of the epidemiological cycle and absence of any type of vaccine or medications, the Government issued various non-pharmacological measures to end the COVID-19 pandemic. Several researchers applied the Susceptible-Infected-Recovered-Deceased (SIRD) compartmental epidemiology process model to identifying the effect of different governments intervention methods enforced to mollify the spread of COVID-19 epidemic. In this paper, we aim to provide a modified SIRD model for COVID-19 spread prediction. We have analyzed the data of the Northern and Southern states of India from January 30, 2020, to October 24, 2020 using the proposed SIRD model and existing SIRD model. We have made the predictions with reasonable assumptions based on real data, considering that the precise course of an epidemic is highly dependent on how and when quarantine, isolation, and precautionary measures were imposed. The proposed method gives better approximation values of new cases, R_0 (Reproductive Number), daily deaths, daily infectious, transmission rate, and recovered individuals. Through the analysis of the reported results, the proposed SIRD model can be an effective method for investigating the effect of government interventions on COVID-19 associated transmission and mortality rate at the time of epidemic.

Keywords Coronavirus; Epidemiological Models; India; Basic Reproduction Number; Model Prediction

1 Introduction

The year 2020 will be remembered by the world as a calamitous year for humankind. The ingenious, newly developing, the agent was classified as a new betacoronavirus and named as Severe Acute Respiratory Syndrome virus coronavirus 2 (SARS-Cov2), genetically related to the SARS-CoV1 [1] that appeared in the year 2003. The SARS-Cov2 associated disease has been named “COVID-19”, which led to COVID-19, later formed a group of pneumonia cases in Wuhan, China. [2]. The outbreak was early detected in 2019 that

Sakshi Shringi
Rajasthan Technical University, Kota
E-mail: sakshi.shringi@gmail.com

Harish Sharma
Rajasthan Technical University, Kota
E-mail: harish.sharma0107@gmail.com

Pushpa Narayan Rathie
University of Brasilia, Brasilia, Brazil
E-mail: rathie@unb.br

Jagdish Chand Bansal
South Asian University, New Delhi
E-mail: jcbansal@gmail.com

Atulya Nagar
Liverpool Hope University, United Kingdom
E-mail: NAGARA@hope.ac.uk

induced a large epidemic in China with the first mortality reported on January 10, 2020 and, is declared a global pandemic by the World Health Organization (WHO) on March 11, 2020, [3] making it a worldwide threat. According to John Hopkins University, there are 42,395,907 confirmed cases of COVID-19 [4] worldwide as of October 24, 2020. The number of confirmed cases in India is 7,862,656, which is 18.5 % of the total confirmed. The Case Fatality Rate(CFR) for India contributes to 1.5 % with 8.67 deaths per 100k population [5]. Different protective measures are imposed by the government for reducing the transmission of COVID-19 such as social distancing, restricting travel, cancellations/postponing events, hard and soft lockdowns, quarantines, and testing [6]. The impact of coronavirus, especially on the economic and social front is even more disastrous than the number of casualties this virus has caused [7]. It is alarming to see the hazard COVID-19 may cause in India, as India contributes 18% of the total world population [8] with Mumbai being the most densely populated city with 32,303 *people/km²* [9]. This shows that novel coronavirus can spread very rapidly in the highly populated country like India. The SARS-Cov2 is transmitted from one individual to another basically by respiratory droplets and causes fever and respiratory symptoms such as shortness of breath, and cough [10]. The SARS-Cov2 incubation period ranges from 2 to 14 days, but typically 5 days [11]. 50% of the people become ill, 5 days after they are infected. Very few cases of children who got infected by COVID-19 are reported [12]. Many precautionary measures were taken by the Government of India to reduce the spread of the virus. The government imposed multiple lockdowns:

1. **Phase 1:** March 25, 2020, to April 14, 2020 (**Lockdown 1.0**), 21 days. Complete lockdown except for essential services. [13]
2. **Phase 2:** April 15, 2020, to May 3, 2020 (**Lockdown 2.0**), 19 days. Conditional relaxations for areas with minimal spread [14].
3. **Phase 3:** May 4, 2020, to May 17, 2020 (**Lockdown 3.0**), 14 days. Depending on the spread of the virus, the districts were divided into three zones-green, red, and orange. The restrictions were imposed accordingly [15].
4. **Phase 4:** May 18, 2020 to May 31, 2020 (**Lockdown 4.0**), 14 days. Declared by National Disaster Management Authority [16]

The government also initiated the unlock:

1. **Phase 1:** June 1, 2020, to June 30, 2020, (**Unlock 1.0**), 30 days. Shopping malls, restaurants and hotels, religious places were allowed to open, with active night curfews from 9 P.M. to 5 A.M. [17].
2. **Phase 2:** July 1, 2020, to July 31, 2020, (**Unlock 2.0**), 31 days. All activities, with suitable restrictions, were permitted in non-contaminated areas. Schools and colleges remained closed. Night curfews were effective from 10 P.M. to 5 A.M. [18].
3. **Phase 3:** August 1, 2020, to August 31, 2020 (**Unlock 3.0**), 31 days. Night curfews were removed. Places like gymnasiums and centres for yoga were open again. Maharashtra and Tamil Nadu were under lockdown for the complete month, while West Bengal continued lockdown twice a week. The permission to celebrate Independence day was granted with all safety measures to be followed. [19].
4. **Phase 4:** September 1, 2020, to September 30, 2020 (**Unlock 4.0**), 30 days. Marriage functions and funerals up to 50 people and 100 people respectively, were permitted. 100 people were allowed to attend religious, political, entertainment, and academic functions with face masks and social distancing. [20]
5. **Phase 5:** October 1, 2020, to October 31, 2020 (**Unlock 5.0**), 31 days. Cinema halls, with 50% seating capacity was permitted to open from October 15. Swimming pools for training the sportsperson was allowed to open [21].
6. **Phase 6:** November 1, 2020, to November 30, 2020 (**Unlock 6.0**), 30 days. The Government of Kerala has opened the tourism sector from November 3, 2020. The Government of India has decided to open schools and colleges by January 2021. The schools will be open from November 16, in Tamil Nadu and by December 2020 in Kerala.

The Press Information Bureau observed that around 36-70 lakh cases and 78,000 deaths were abstained, due to the imposition of these lockdowns [22]. As given by WHO, though many medical organizations are heading fast towards vaccine development, currently, there is no vaccine or anti-viral treatments available and it may take at least 18-20 months before it is available [23] or even more to be available for everyone. In such a situation, it is very essential to understand the course of the epidemic. The predictive mathematical models for epidemics can be used to estimate the future of COVID-19 worldwide [24].

This may help to prepare control strategies in advance and was elucidated by the recent Ebola epidemic [25]. The compartmental models are the best way to understand the epidemic [26]. In these models, the population is divided among 3 compartments/sub-populations: Susceptible (S), Infected (I) and Recovered (R) [27]. In such models, the epidemic outbreak ends once the threshold of "herd immunity" is achieved i.e. when the susceptible population impoverishes to a point where less than one person is infected by the infected person from the disease. Various mathematical models have been developed to understand the transmission dynamics of COVID-19. Chen et al. [28] proposed a Bats-Hosts-Reservoir-People network model to simulate the possible transmission from the infection source (probably bats) to human infection. Their results showed that the value of R_0 was 2.30 from source to person and 3.58 from person to person. Liu et al. [29] extended the basic SIR model by adding a new compartment that evaluates the state of exposed individuals that have been infected but are not yet infectious, named the SEIR model. After recovery, if a person again becomes susceptible, the SEIR model can be used.

Anwarud et al. [30] used random variables for predicting the impending states by using continuous time Markov Chain (CTMC) through stochastic model method. Naik et al. [31] analyzed the transmission of COVID-19 epidemic by implementing the fractional-order epidemic model having two different operators known as classical Caputo and Atangana-Baleanu-Caputo operators. Qureshi & Atangana [32] designed an epidemiological model with newly devised fractal fractional Caputo type operator for graphical analysis of diarrhea transmission dynamics that first appeared in Ghana during 2008-2018. Ahmed et al. [33] used both the Ordinary Differential Equation (ODE) and Fractional Differential Equation to describe the outbreak of COVID-19. Jajarmi et al. [34], extensively investigated the fraction version of SIRS model for HRSV disease. They used a new derivative operator with Mittag-Leffler kernel in Caputo sense (ABC) and applied the fixed-point theory to present the uniqueness of the solution for the model under consideration. Tuan et al. [35] proposed a new mathematical model with eight mutually different compartments with the help of Caputo type memory-possessing operator. They showed that the proposed model had a unique solution when used with Banach fixed point analysis, with basic reproductive number R_0 equals to 6.5894, approximately. Ahmed et al. [36] proposed a fractional order model consisting of a system of five nonlinear fractional-order differential equations in the Caputo sense to analyse the significance of the lockdown in reducing the spread of coronavirus.

In case of large COVID-19 dataset, the predicted values of β and coefficient of prediction $predR^2$, fails to give better approximation using the models available in the literature. In COVID-19 mortality rate is lower whereas the infection spreading is higher as compared to previous diseases such as SARS, MERSs, and even Ebola, therefore it is much more pervasive. The death rate from COVID-19 exceeded five times that of SARS after just 3 months. The results obtained by the proposed SIRD model predicts the near accurate values of daily deaths, daily infected, new cases, reproductive number and transmission rate. The predictions achieved from the proposed model can be used by the national and states government authorities, researchers, and service managers to plan the medical infrastructure and other strategies in advance.

In this paper, we have used the Susceptible-Infected-Recovered-Deceased (SIRD) compartmental epidemiology process model for analysis. In this model, a person recovers or dies once infected. Unlike the standard formulation, our model works on the following assumptions:

1. The individual transitions between the compartments changes dynamically and hence, it is time-dependent.
2. The frequency of non-pharmaceutical inferences, directly affects the time-dependency. Hence, the estimation of simultaneous decline in the transmission rate of the disease may help to evaluate the performance of these inferences.

We have examined the progress of the COVID-19 epidemic through the proposed model. We have applied this model on 17 States and Union-Territories(UT) of North and South parts of India. The model is divided into four different stages of infection namely; Susceptible (**S**), Infected (**I**), Recovered (**R**) and Dead (**D**).

The remaining paper is structured as follows: Section 2 explains the Modeling framework and design. In Section 3, we have discussed the analysis results for all the states. Section 4 concludes the work performed.

2 Modelling Framework and Design

We employ the standard SIRD Model where the total population N is further divided into sub-population of Susceptible (S), Infected (I), Recovered (R), and Dead (D) at time t .

2.1 The SIRD Model

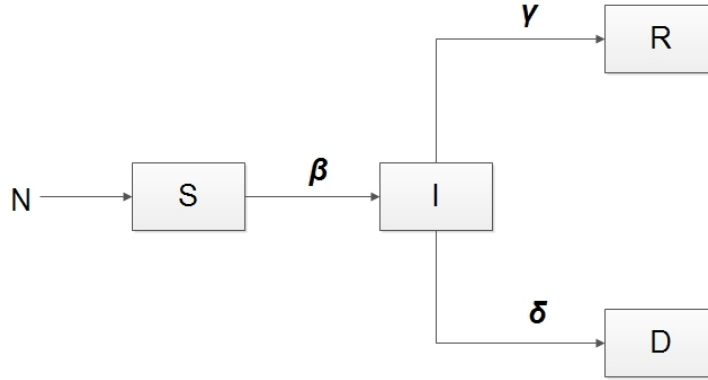

Fig. 1: The SIRD Model

The total population N is given by:

$$N = S_t + I_t + R_t + D_t \quad (1)$$

The change in total number of cases is given by:

$$C_t = I_t + R_t + D_t \quad (2)$$

The value of the total population from equation (1) is approximately a constant. The value of SIRD compartments can be calculated by the equations:

$$S_{t+1} = S - \left(\frac{\beta SI}{N}\right) \quad (3)$$

$$I_{t+1} = I + \left(\frac{\beta SI}{N}\right) - \gamma I - \delta I \quad (4)$$

$$R_{t+1} = R + \gamma I \quad (5)$$

$$D_{t+1} = D + \delta I \quad (6)$$

Initially, the total number of susceptibles (S) were nearly equal to the total population (N). The exponential growth rate (r_0) (per day growth rate) and the basic Reproductive Number (R_0) (dimensionless) can be evaluated by the following equation:

$$r_0 = \beta - (\gamma + \delta) \quad (7)$$

$$R_0 = \frac{\beta}{\gamma + \delta} \quad (8)$$

The epidemic evolves when $R_0 > 1$ ($r_0 > 0$), otherwise perishes.

Evaluating the impact of government measures on the epidemic

Assume that the daily change in number of susceptibles is formulated as $\Delta S = S_{t+1} - S_t$. The daily change in number of Infected, Recovered and Deaths can be calculated similarly by the following equations:

$$\Delta S = \frac{-\beta SI}{N} \quad (9)$$

$$\Delta I = \left(\frac{\beta SI}{N}\right) - \gamma I - \delta I \quad (10)$$

$$\Delta R = \gamma I \quad (11)$$

$$\Delta D = \delta I \quad (12)$$

Determining the above equations for transmission coefficient, recovery and death rates.

In the earlier days of data collection $C_t = I_t + R_t + D_t$ is very small as compared to N, making N very close to S_t , then we can take $\beta = \Delta C/I$, but for large data, which is the case that we are considering in our analysis, the value of C_t is not that small and we need more accurate values. Hence, we have modified the existing model and the new value of β is derived as:

From equation (9),

$$\Delta I + \gamma I + \delta I = \frac{\beta SI}{N} \quad (13)$$

From equation (2), (11) and (12),

$$\Delta C = \frac{\beta SI}{N} \quad (14)$$

From equation (1),

$$\Delta C = \frac{\beta(N - C)I}{N} \quad (15)$$

$$\beta = \left(\frac{\Delta C}{I}\right) * N/(N - C) \quad (16)$$

$$\gamma = \frac{\Delta R}{I} \quad (17)$$

$$\delta = \frac{\Delta D}{I} \quad (18)$$

In the case when $N = S$, beta values will be smaller (implying smaller R_0 values) than the beta values obtained by taking $N = S + C$ (implying larger R_0 values). This will result in incorrect prediction decisions when $N=S$, especially when R_0 is very close to 1.

We can determine the SIRD parameters for each day with the help of N, C, I, R, and D values. Table 1 illustrates the SIRD model parameters used for analysis of COVID-19 epidemic.

The values of parameters obtained will have a lot of noise due to the process and measurement.

1. **Process Noise:** As long as the number of infected individuals is comparatively small in the initial phase of the pandemic, the process noise is predicted to be approximately high.
2. **Measurement Noise:** Fundamentally, measurements are never splendid. The measurement/observation noise can occur due to many reasons:
 - (a) Interruption in reporting daily cases.
 - (b) As the realization of epidemic escalates, identification of new COVID-19 cases is expected to increase deliberately. Since many cases of COVID-19 are asymptomatic, the proportion of asymptomatic cases tested will highly affect the number of cases reported as many cases maybe wrongly classified as pneumonia or influenza.
 - (c) The understanding of "Infected" and "Recovered" by the government authorities while collecting data.

The process and measurement noise can be reduced by smoothing the data of daily changes. This will also help to reduce the complications in data pattern, as the results are only informative till we can filter the effects of various errors caused due to imprecise reports.

Table 1: SIRD Model Parameters and Definition

S. No.	Parameter	Definition
1.	N	Total Population
2.	S	Susceptible Individuals
3.	I	Infected Individuals
4.	R	Recovered Individuals
5.	D	Number of Deaths
6.	C	Change in number of cases
7.	β	Coefficient of Transmission
8.	γ	Rate of Recovery
9.	δ	Rate of Deaths

2.2 Model Specifications

2.2.1 Data set description

In this paper, the dataset of COVID-19 is collected from COVID19 INDIA [37] and is highly contingent due to dependency of increment/decrement in total cases on physical variables. The dataset comprises 37 exclusive time-series data of confirmed, recovered and deceased cases of States (28) and Union Territories (9) of India. Table shows that we have analyzed the State and Union Territories data of North India and South India in this paper from January 30, 2020, to October 24, 2020.

2.2.2 Methodology

With the help of available time-series data of daily cases we can calculate some extra time-series:

1. The number of New Cases

$$\Delta C = C_{t+1} - C_t \quad (19)$$

2. The number of Infected/Active Cases

$$\Delta I = C_t - (R_t + D_t) \quad (20)$$

3. The number of Daily Deaths

$$\Delta D = D_{t+1} - D_t \quad (21)$$

We use the above equations to calculate the daily estimates of SIRD parameters.

Further, we smooth the data to remove the process and measurement noise. For smoothing of data, we use the *Locally Weighted Scatterplot Smoothing (LOWESS)*[38]. It is a popular tool used in Regression Analysis that creates a smooth line through a timeplot/scatterplot to see the relationship between variables and foresee trends. We have used the fraction of 0.1 for β and δ and fraction of 0.2 for γ . The fraction values are estimated on the basis that if we increase the value of fractions, we will move towards the straight line instead of curves.

The parameters are smoothed only after C_t exceeds 100 cases, as the data is very noisy for small values. The value of parameters is constant until C_t reaches 100 cases and is set equal to the first smoothed value.

Applying the smoothed estimation of model parameters, we have solved the SIRD model ahead of time for the duration of the epidemic. The initial values of SIRD model is assumed as: $S(0)=N$, $R(0)=D(0)=0$ and the value $I(0)$ is estimated from data.

The coefficient of prediction R^2 is used to measure the fit of our model and is calculated using the following equation:

Table 2: Data sets(source: covid19india.org)

S. No.	State/UT Name	Confirmed	Recovered	Deceased	Tested	Date Range	Population
1.	Andaman and Nicobar Islands	4225	3968	58	81880	Mar 26, 2020 to Oct 24, 2020	4L
2.	Andhra Pradesh	804026	765991	6566	7502933	Mar 12, 2020 to Oct 24, 2020	5.2Cr
3.	Chandigarh	13977	13087	216	100797	Mar 19, 2020 to Oct 24, 2020	11.8L
4.	Delhi	352520	319828	6225	4315339	Mar 02, 2020 to Oct 24, 2020	2Cr
5.	Haryana	157064	145196	1720	2505052	Mar 04, 2020 to Oct 24, 2020	2.9Cr
6.	Himachal Pradesh	20213	17296	285	365838	Mar 14, 2020 to Oct 24, 2020	73L
7.	Jammu and Kashmir	91329	82219	1430	2153529	Mar 09, 2020 to Oct 24, 2020	1.3Cr
8.	Karnataka	798378	700737	10873	7281090	Mar 09, 2020 to Oct 24, 2020	6.6Cr
9.	Kerala	386088	287261	1307	4280204	Jan 30, 2020 to Oct 24, 2020	3.5Cr
10.	Ladakh	5913	5052	71	71063	Mar 07, 2020 to Oct 24, 2020	2.9L
11.	Puducherry	34112	29614	586	289689	Mar 17, 2020 to Oct 24, 2020	15L
12.	Punjab	130640	122256	4107	2457574	Mar 09, 2020 to Oct 24, 2020	3Cr
13.	Rajasthan	184422	165496	1826	3609151	Mar 03, 2020 to Oct 24, 2020	7.7Cr
14.	Tamil Nadu	706136	663456	10893	9436817	Mar 03, 2020 to Oct 24, 2020	7.6Cr
15.	Telangana	230274	209034	1303	4052633	Mar 03, 2020 to Oct 24, 2020	3.7Cr
16.	Uttar Pradesh	468238	433703	6854	13908303	Mar 04, 2020 to Oct 24, 2020	22.5Cr
17.	Uttarakhand	60155	54169	984	967258	Mar 15, 2020 to Oct 24, 2020	1.1Cr

Table 3: Values of coefficient of prediction for all States/UT of India

S. No.	Name of States/UT	SIRD Model		Modified SIRD Model	
		$predR^2$ (Before Smoothing)	$predR^2$ (After Smoothing)	$predR^2$ (Before Smoothing)	$predR^2$ (After Smoothing)
1.	Andaman and Nicobar Islands	-0.8552	-0.7783	-0.4945	0.9996
2.	Andhra Pradesh	-0.6385	-67.4244	0.1028	0.9991
3.	Chandigarh	-0.554	-0.357	-0.3091	0.9971
4.	Delhi	-0.9048	0.7416	-0.9087	0.9259
5.	Haryana	-0.571	-0.6185	-0.4425	0.9979
6.	Himachal Pradesh	-0.5427	0.9573	-0.4543	0.9984
7.	Jammu and Kashmir	0.4218	0.7841	0.3831	0.997
8.	Karnataka	-167.6461	0.6471	-201.837	0.999
9.	Kerala	-0.3878	0.9989	-0.34	0.9793
10.	Ladakh	-0.7706	-7064.6204	-0.7047	0.997
11.	Puducherry	-810.3439	-76.6822	-1556.0079	0.992
12.	Punjab	-41.3734	0.9923	-39.1807	0.995
13.	Rajasthan	-0.7351	-0.7178	-0.6721	0.9996
14.	Tamil Nadu	0.4401	-515.5209	0.5228	0.9989
15.	Telangana	-0.6676	0.5687	-0.4605	0.9914
16.	Uttar Pradesh	-0.6153	0.9788	-0.3921	0.9991
17.	Uttarakhand	-0.6347	0.9836	-0.4277	0.9928

$$predR^2 = 1 - \frac{\sum(Y - X)^2}{\sum[X - mean(X)]^2} \quad (22)$$

where: Y represents Confirmed and Recovered cases for model predictions and X is the data. The coefficient of prediction can reach negative values when the model prediction is worst as compared to the mean of data. For perfect prediction, $predR^2$ reaches 1. The value of $predR^2$, before smoothing and after smoothing is illustrated in Table 3. The after smoothing value shows that our model best fits the given data.

3 Experimental Results

The first case of Covid-19 in India was reported on January 30, 2020, to WHO [39]. Based on the behaviour of the number of confirmed cases in North India and South India, the states are divided into three categories:

1. States Badly Hit by Covid-19
2. State showing a second and third wave of new cases
3. states showing similar trends

3.1 Results Analysis and Observations of the States Badly Hit by Covid-19

3.1.1 Kerala

The first case of the COVID-19 was confirmed on January 30, 2020, in Thrissur district of Kerala (also first case of India). From Figure 2, we can observe that the number of active infected cases began to escalate from the mid of March and reached the highest point by end of September with 67,140 cases. Despite the fact that, Kerala was exalted both nationally and internationally at the beginning for containing Covid-19, a major hike can be seen in the number of cases in late-October. The number of daily deaths increased subsequently from the end of July and reached the spike in the end of September with 29 deaths on September 30, 2020. The case fatality ratio (CFR) of Kerala is 0.34%, the lowest in India compared to other states. The highest number of new cases were confirmed on October 9, 2020, with 11,755 cases, which started declining later. The epidemic thrived in Kerala in mid of May resulting in a "second wave" of new cases with the Reproductive Number(R_0) greater than 1. The current recovery rate is 77% with 2,87,261 recoveries.

3.1.2 Haryana

The first case of the COVID-19 was reported on March 4, 2020. From Figure 3, we observe that the highest active infected cases are on September 16, 2020, with 21,334 cases which declined to 10,148 cases by October 24, 2020. The number of daily deaths is observed to be highest on September 19, 2020, with 29 deaths in one day. So far, 1720 deaths have been reported in Haryana due to the Covid-19 pandemic. The number of new cases is observed highest in the third week of September with 2783 cases on September 11, 2020. The value of R_0 was greater than 1 from the mid of March to the second week of September and started declining at the end of September. The current recovery rate of Haryana is 81.9% with 1,45,196 recoveries.

3.2 Results Analysis and Observations of the State showing second and third wave of new cases

3.2.1 Delhi

The first case of Covid-19 was reported on March 2, 2020, in Delhi. From Figure 4, we observe that the third-highest number of confirmed cases are reported in Delhi with 3,52,520 cases. The total number of active infected people reported are first observed highest on June 27, 2020, with 28,329 infected people resulting in a "second wave" of new cases. The number of cases started declining at the end of June. The hike in active infected cases was again observed on September 20, 2020, with 32,097 cases, resulting in a third wave of new cases.

- 1st Wave: From the beginning to July.
- 2nd Wave: July to September.
- 3rd Wave: September to present.

The number of daily deaths in Delhi is highest in June with 437 deaths on June 15, 2020, gradually declining thereafter. The maximum number of new cases was observed on June 22, 2020, with 3947 cases, and September 15, 2020, with 4473 cases. As of June 27, 2020, the exponential growth rate of Covid-19 epidemic in Delhi began to decrease below 1 and remained the same. The epidemic started thriving again on October 4, 2020. The recovery rate in Delhi is 90% with 3,19,828 recoveries on October 24, 2020.

3.3 Results Analysis and Observations of States showing similar trends

The Figures 5, 6, 7, 8, 9, 10, 11, 12, 13, 14, 15, 16, 17, and 18 respectively shows the COVID-19 situation in the states Andaman and Nicobar Islands, Andhra Pradesh, Chandigarh, Delhi, Haryana, Himachal Pradesh, Jammu and Kashmir, Karnataka, Kerala, Ladakh, Puducherry, Punjab, Rajasthan, Tamil Nadu, Telangana, Uttar Pradesh, and Uttarakhand. It is observed that there is a similar trend in active infected cases, the number of deaths, new cases reported, recoveries, and the growth of the epidemic in the figures. The highest number of infected cases in these states can be seen at the beginning of September and gradually decreasing thereafter. The highest number of daily deaths are observed in the first week of

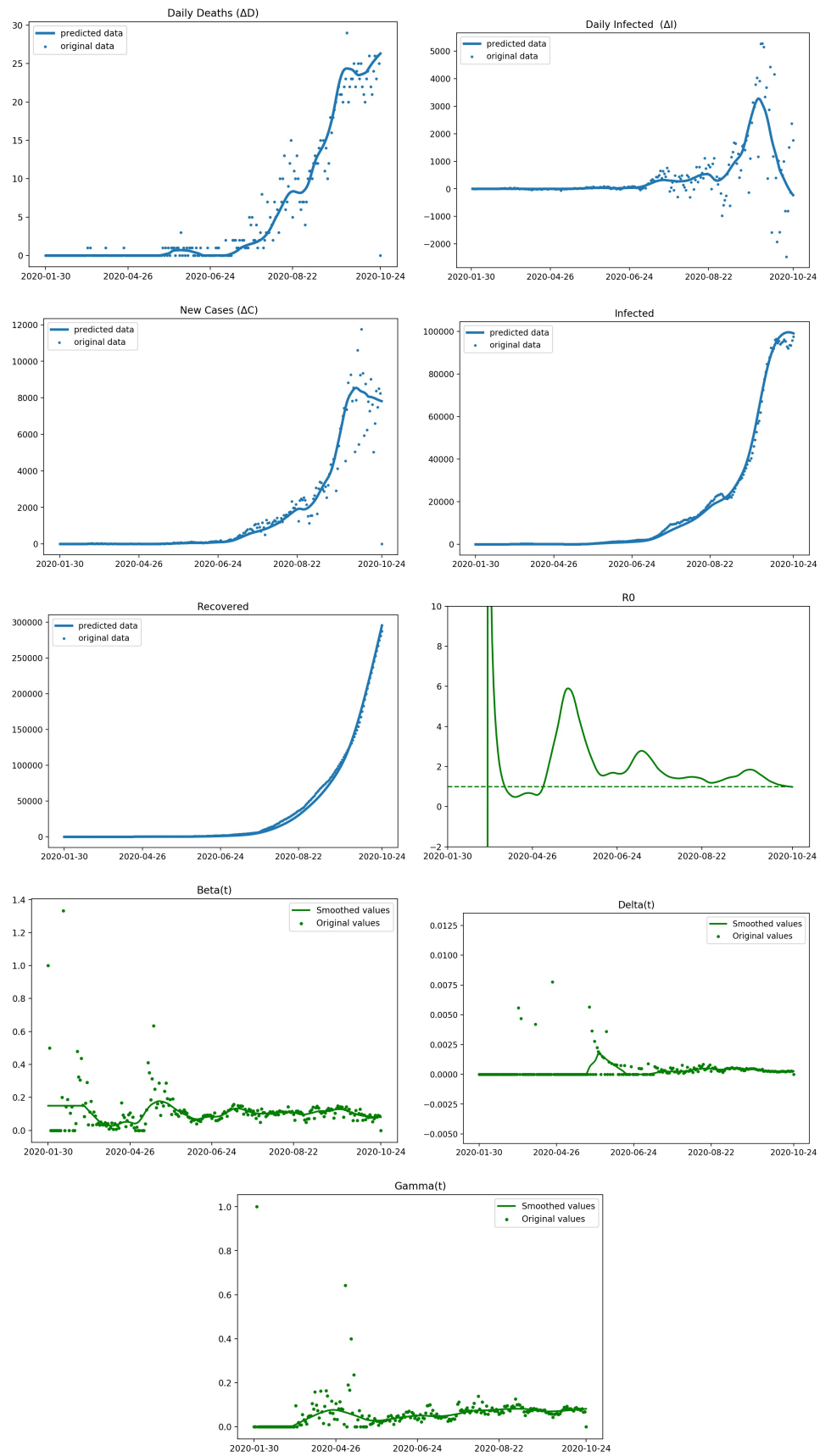

Fig. 2: Graphs of Kerala

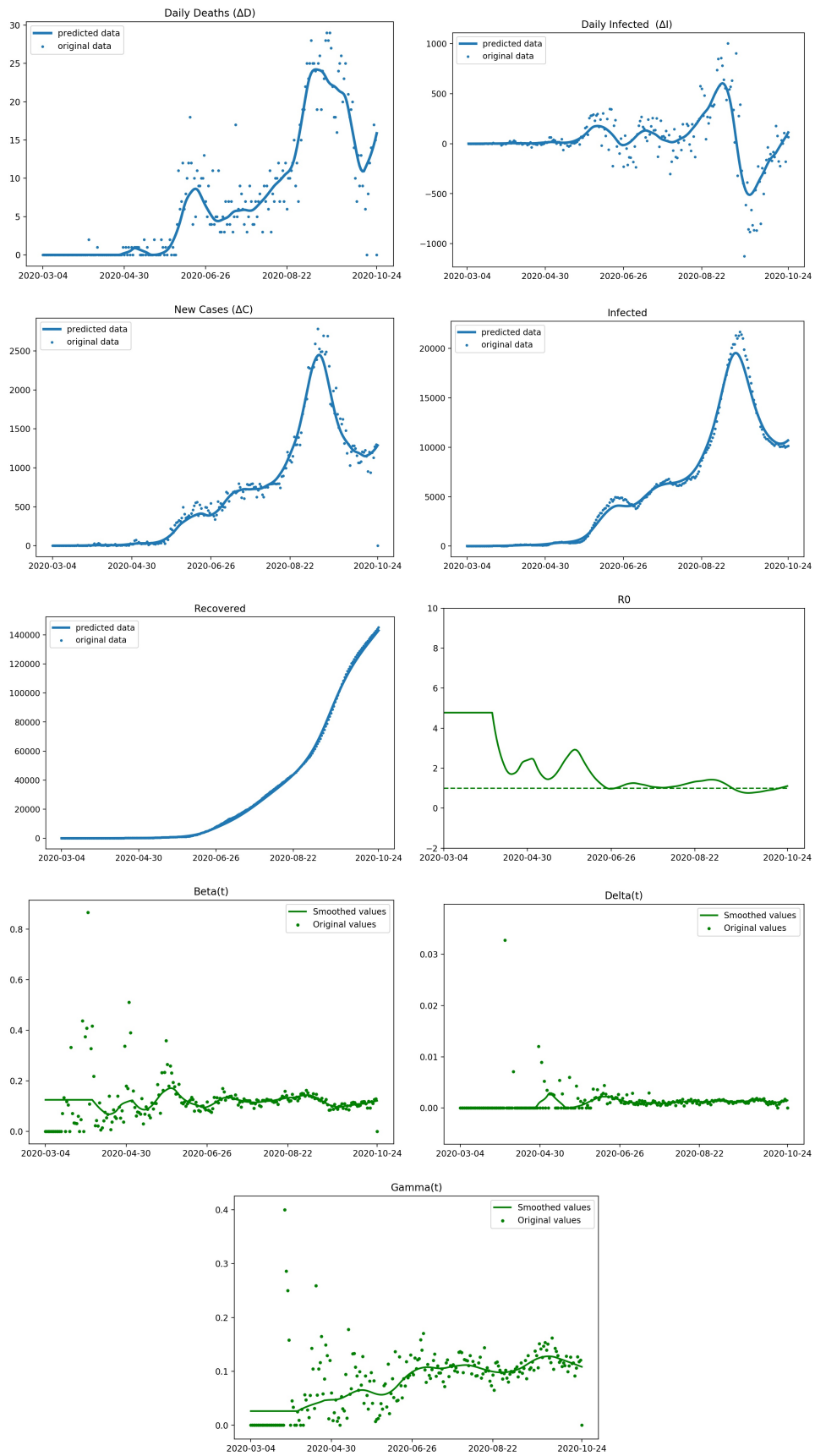

Fig. 3: Graphs of Haryana

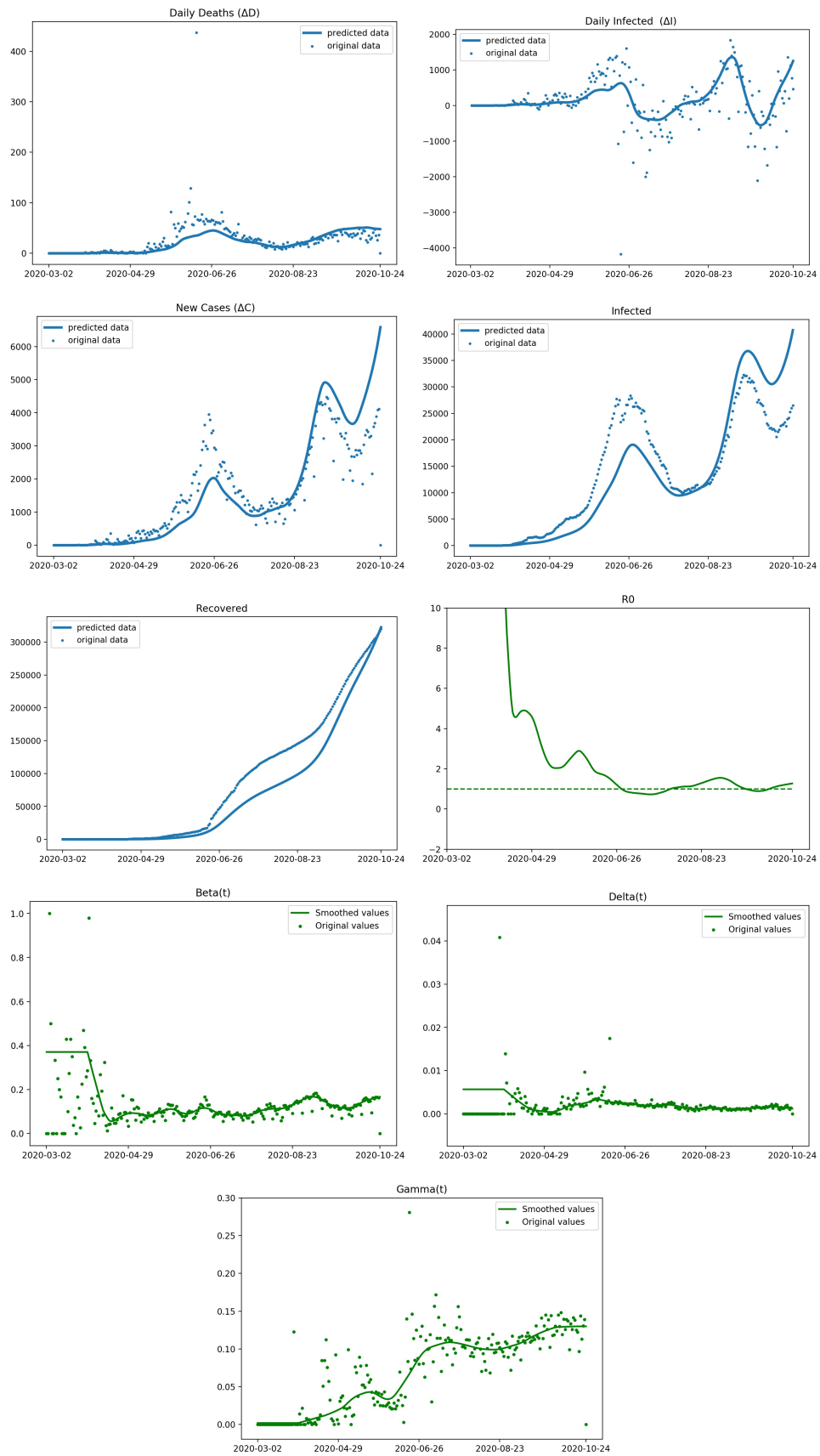

Fig. 4: Graphs of Delhi

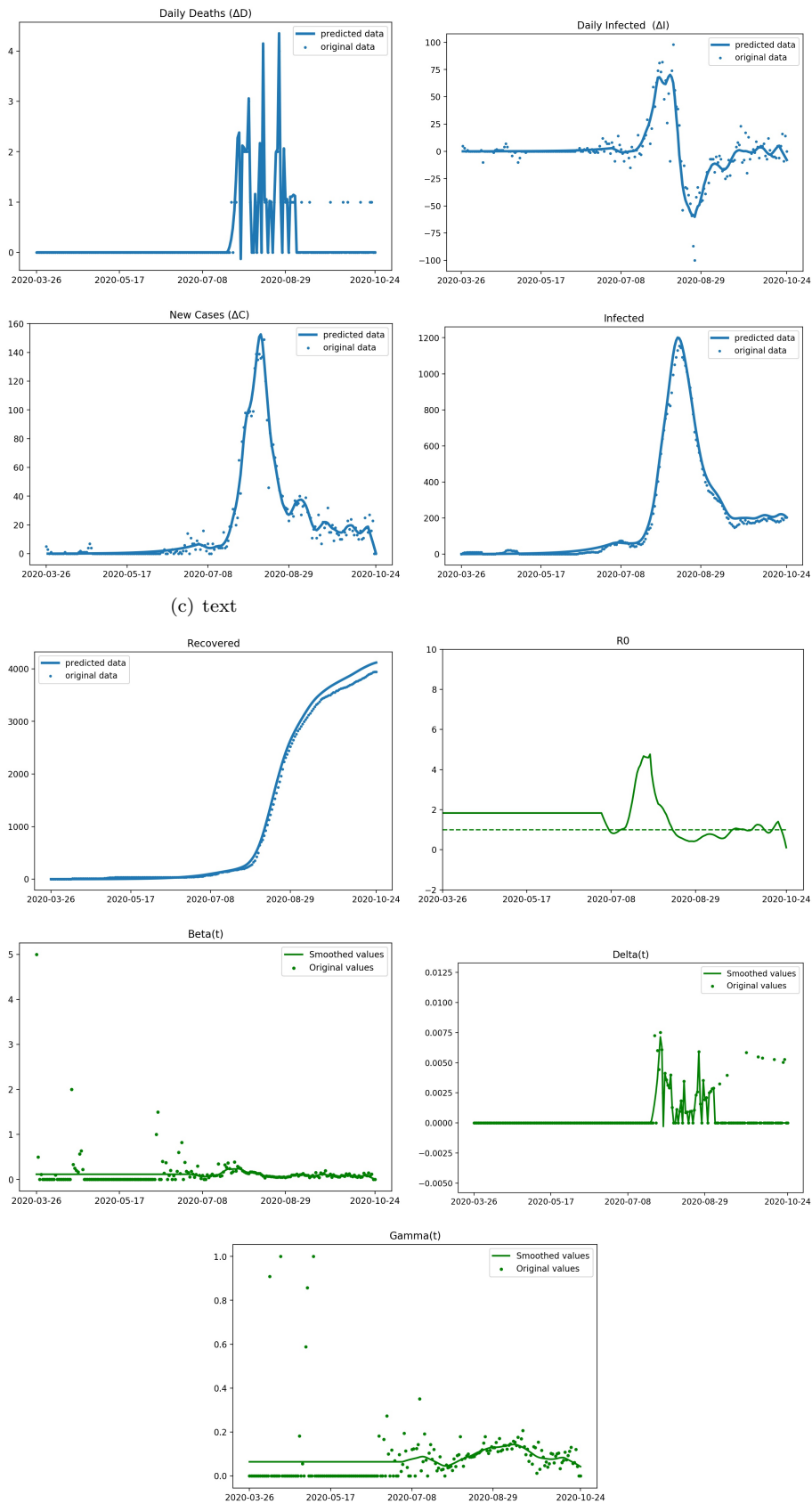

Fig. 5: Graphs of Andaman and Nicobar Islands

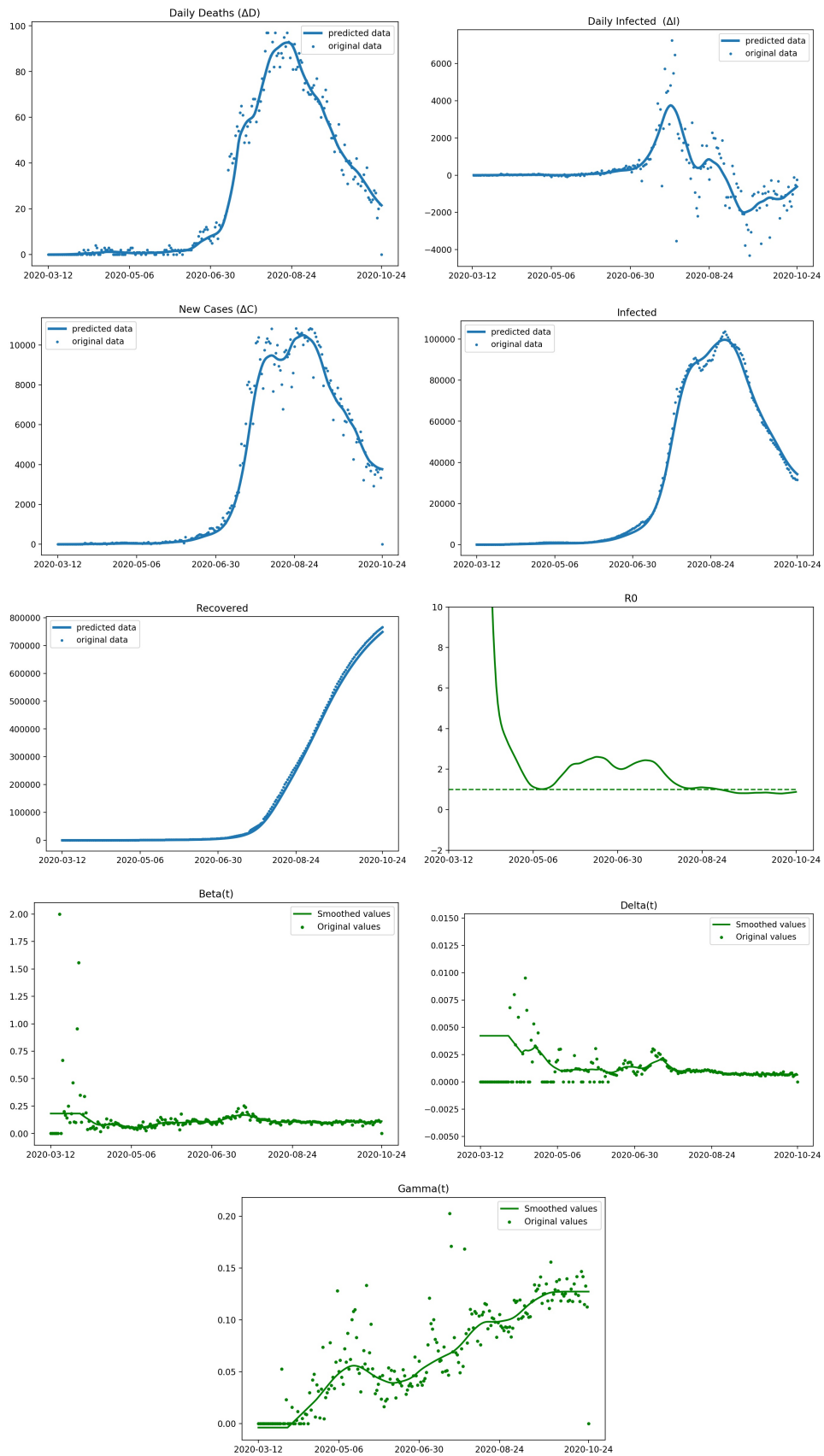

Fig. 6: Graphs of Andhra Pradesh

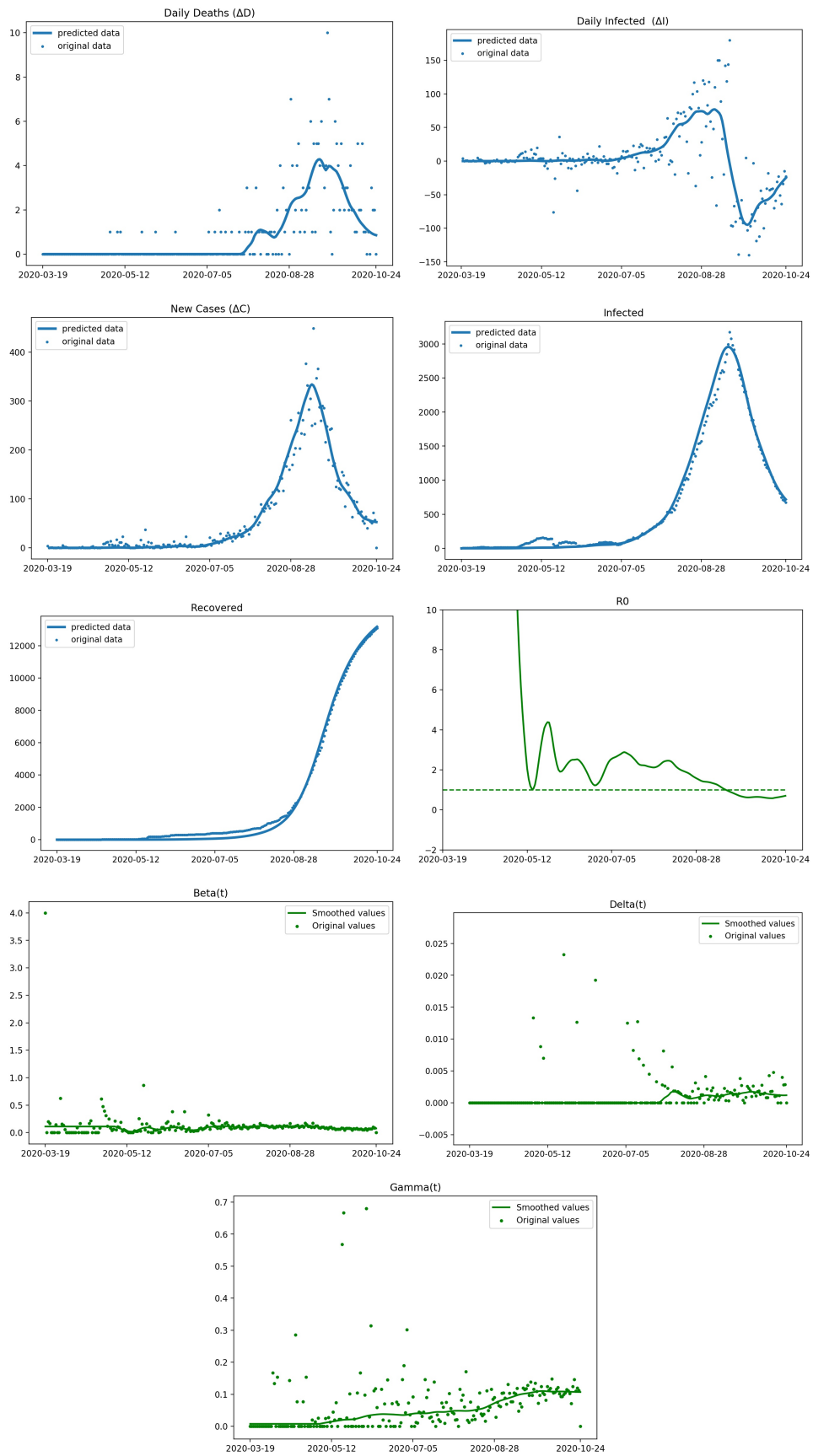

Fig. 7: Graphs of Chandigarh

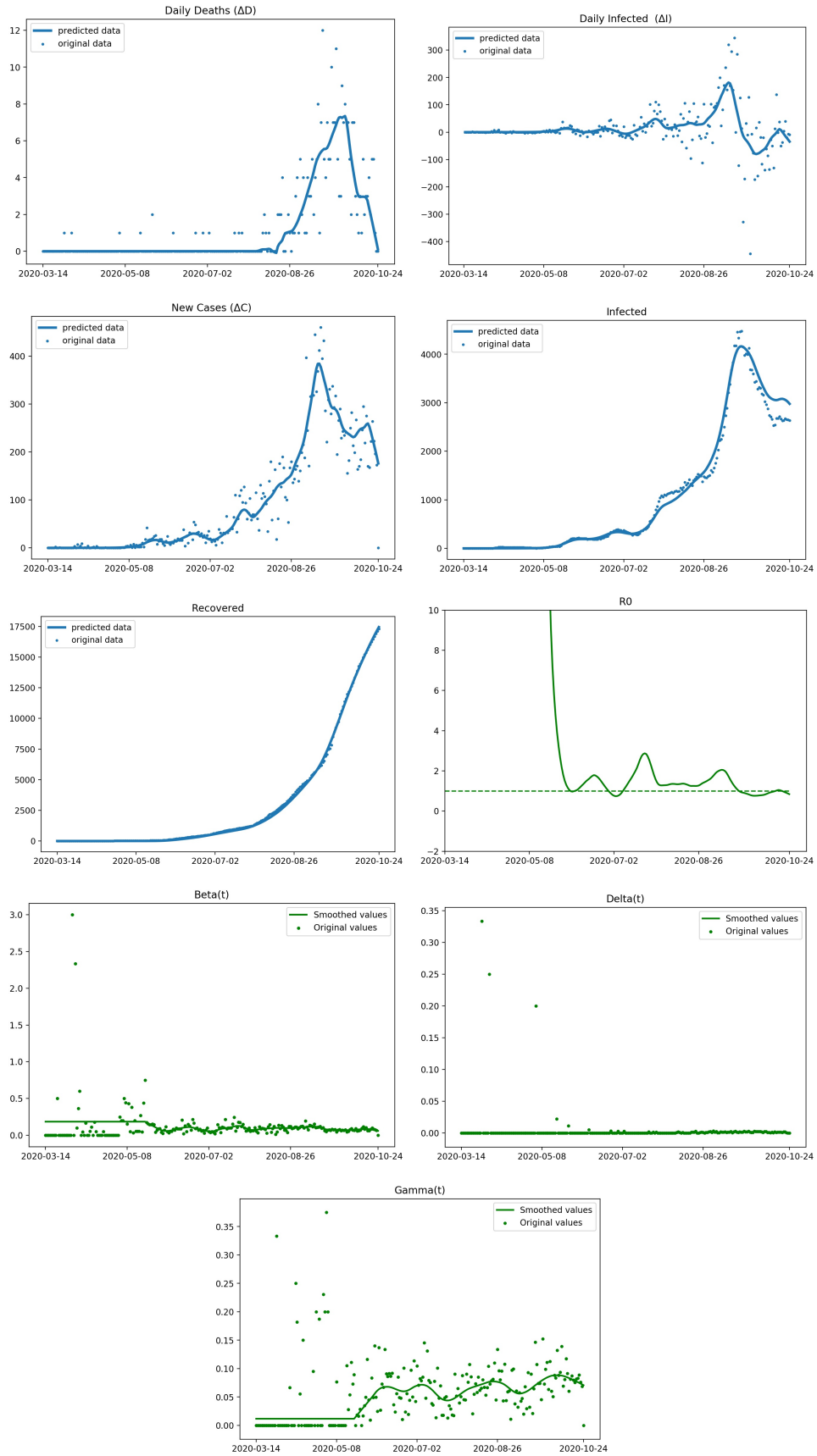

Fig. 8: Graphs of Himachal Pradesh

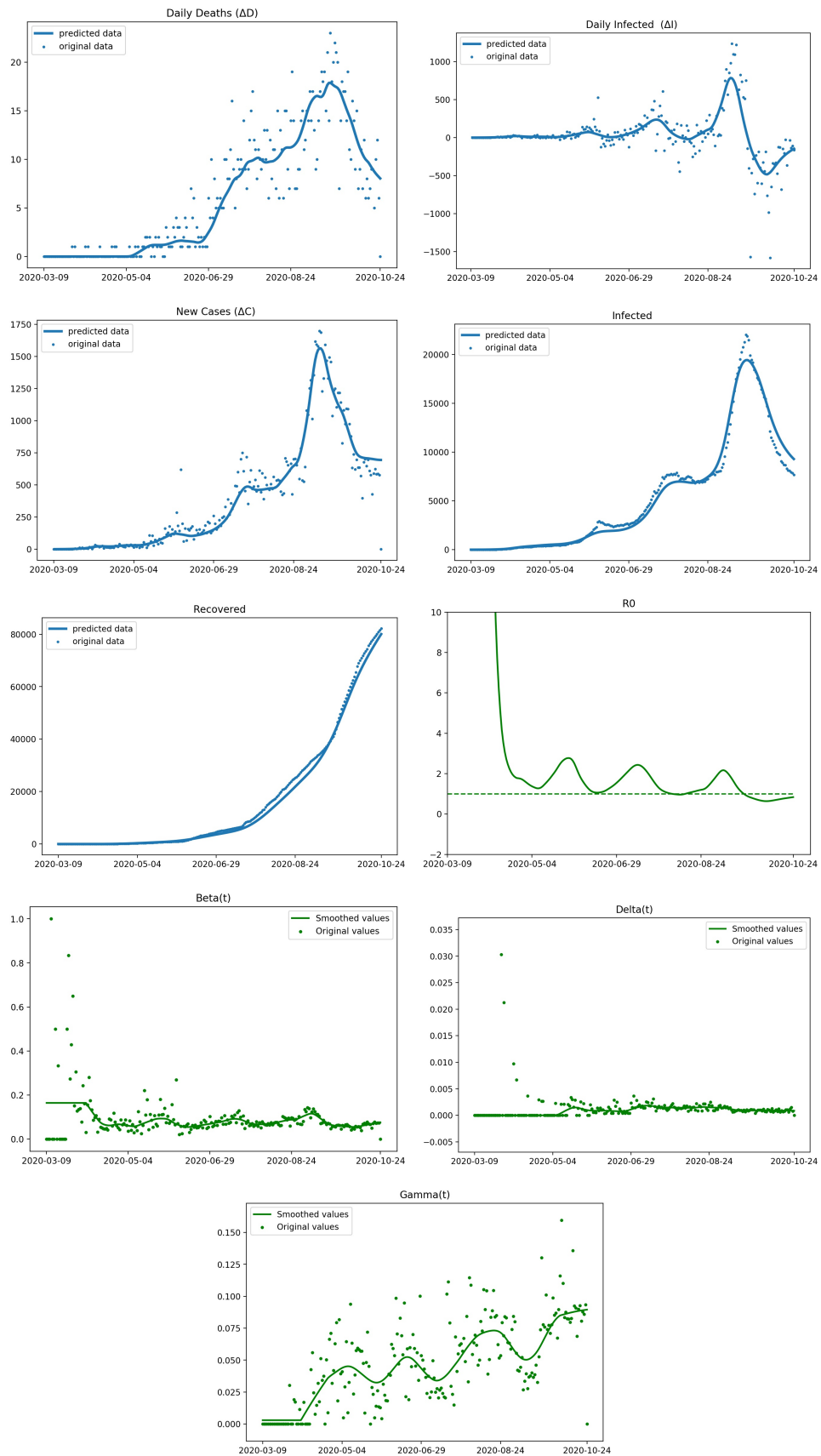

Fig. 9: Graphs of Jammu and Kashmir

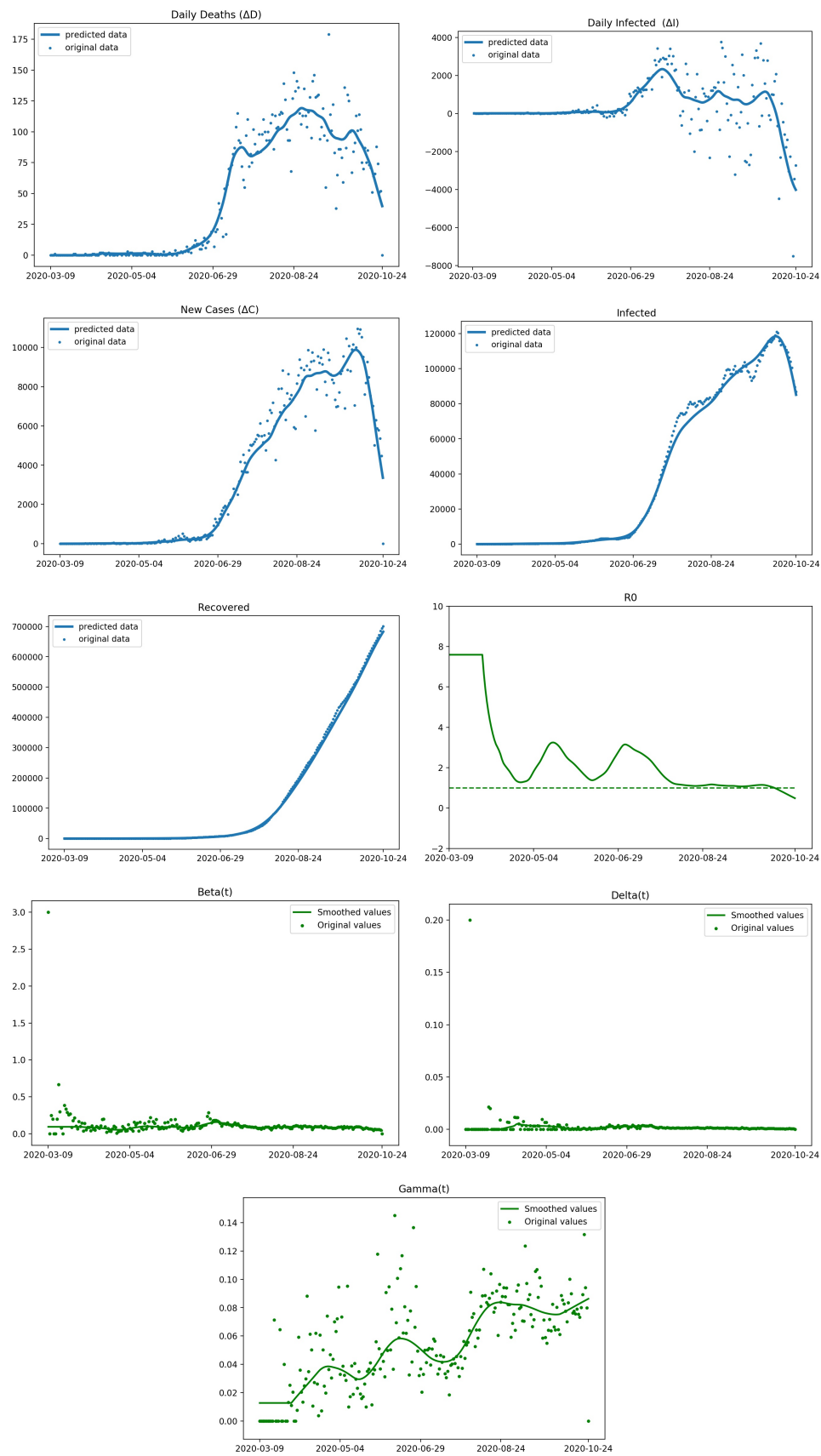

Fig. 10: Graphs of Karnataka

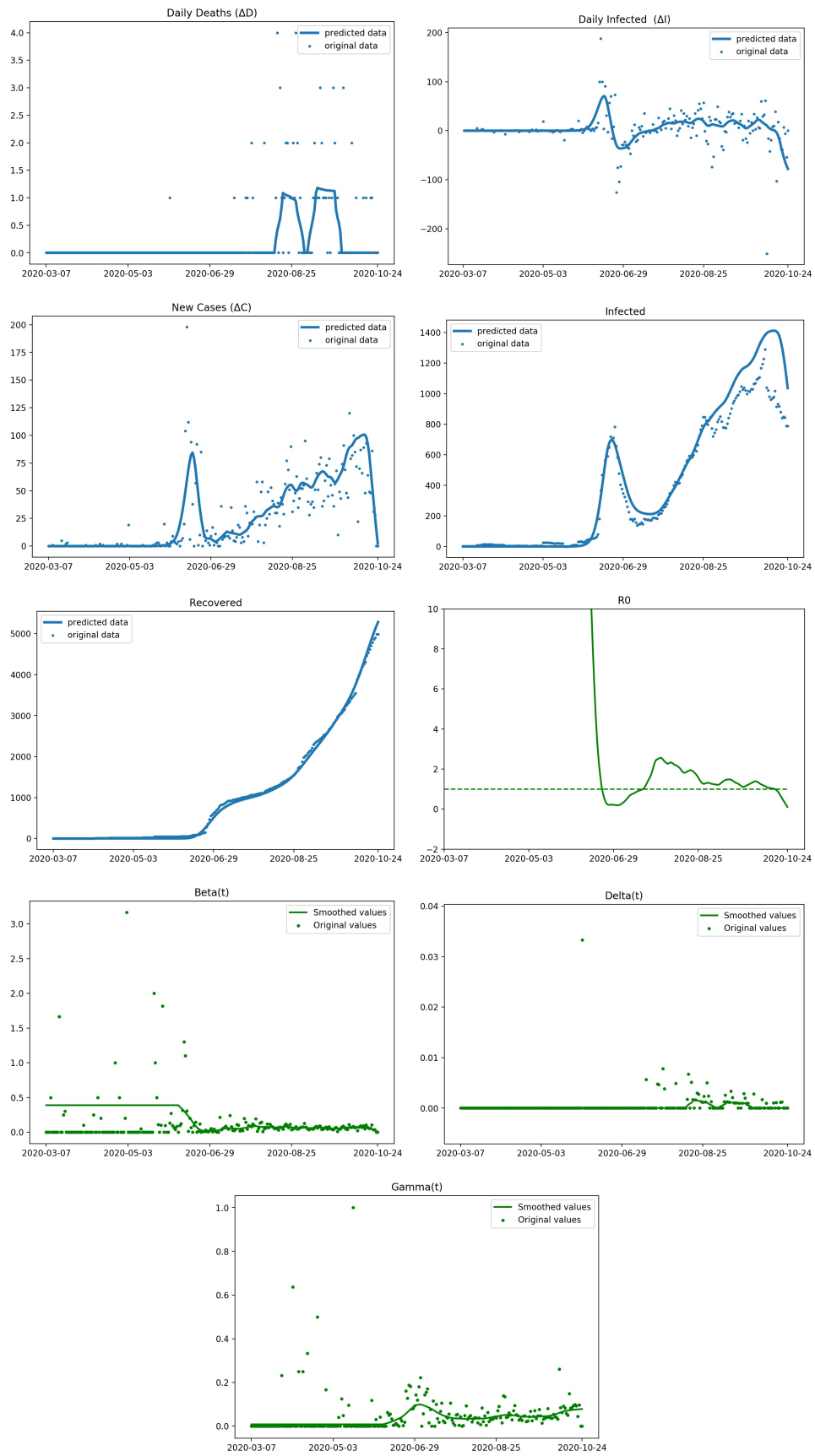

Fig. 11: Graphs of Ladakh

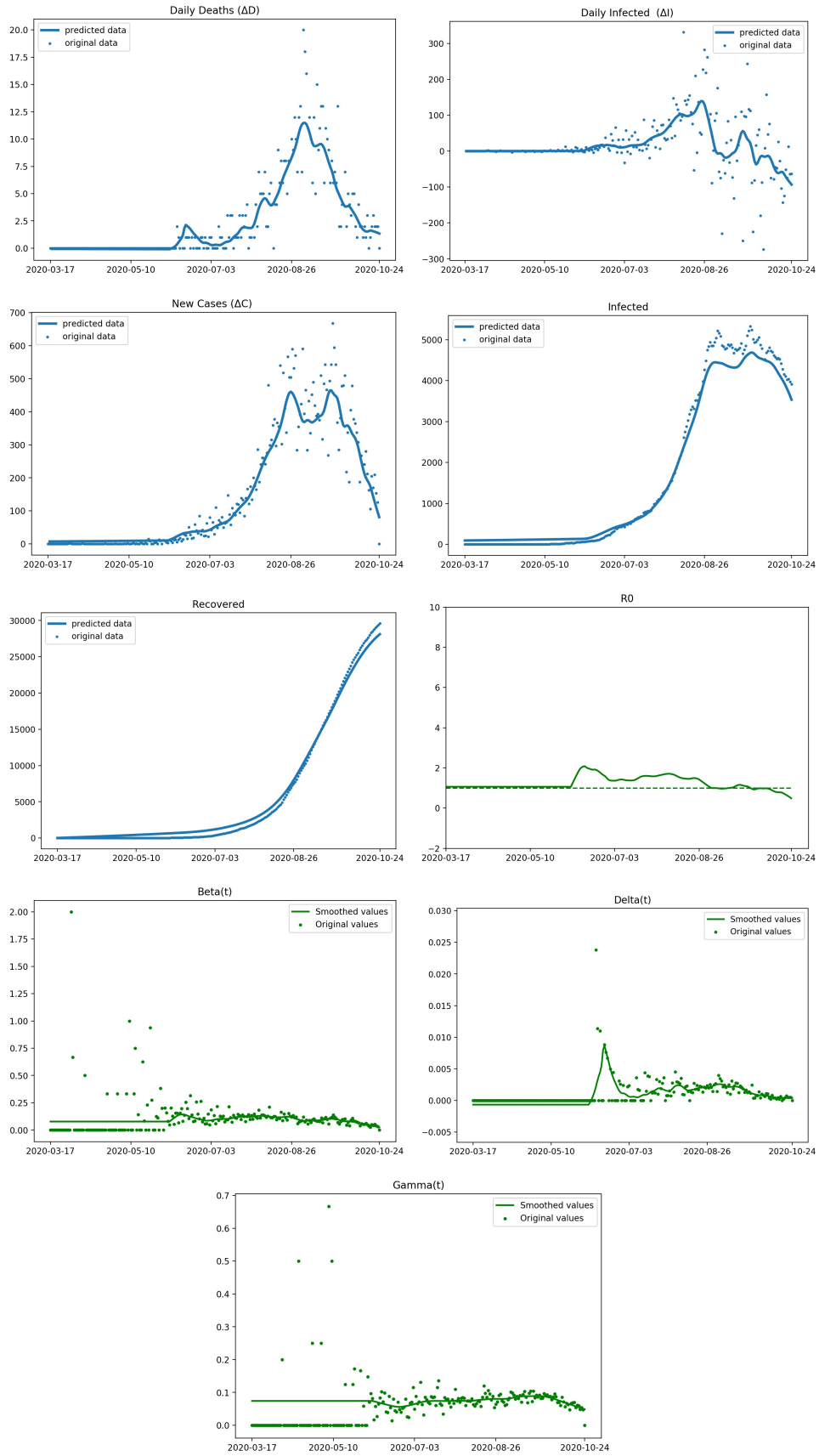

Fig. 12: Graphs of Puducherry

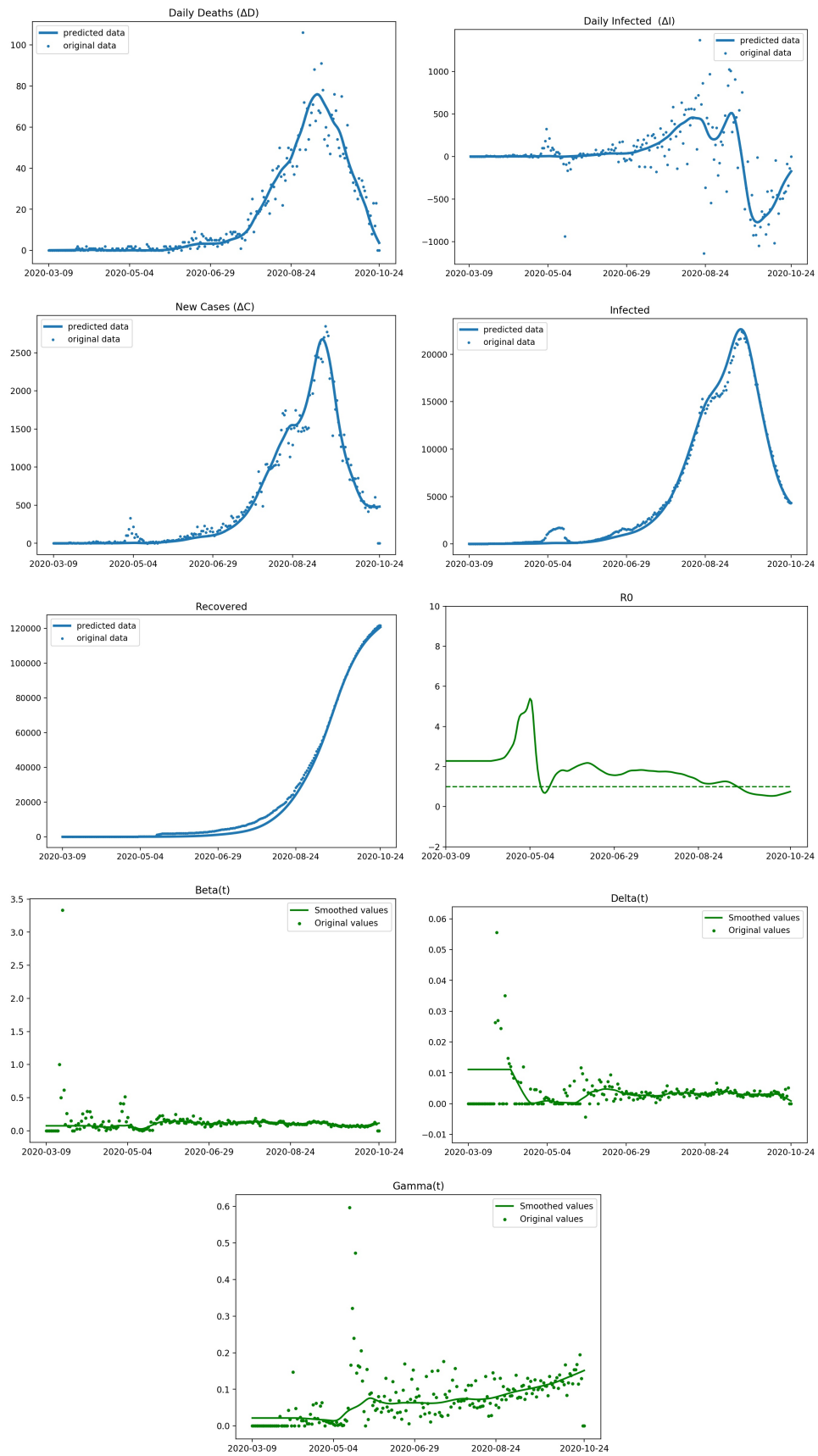

Fig. 13: Graphs of Punjab

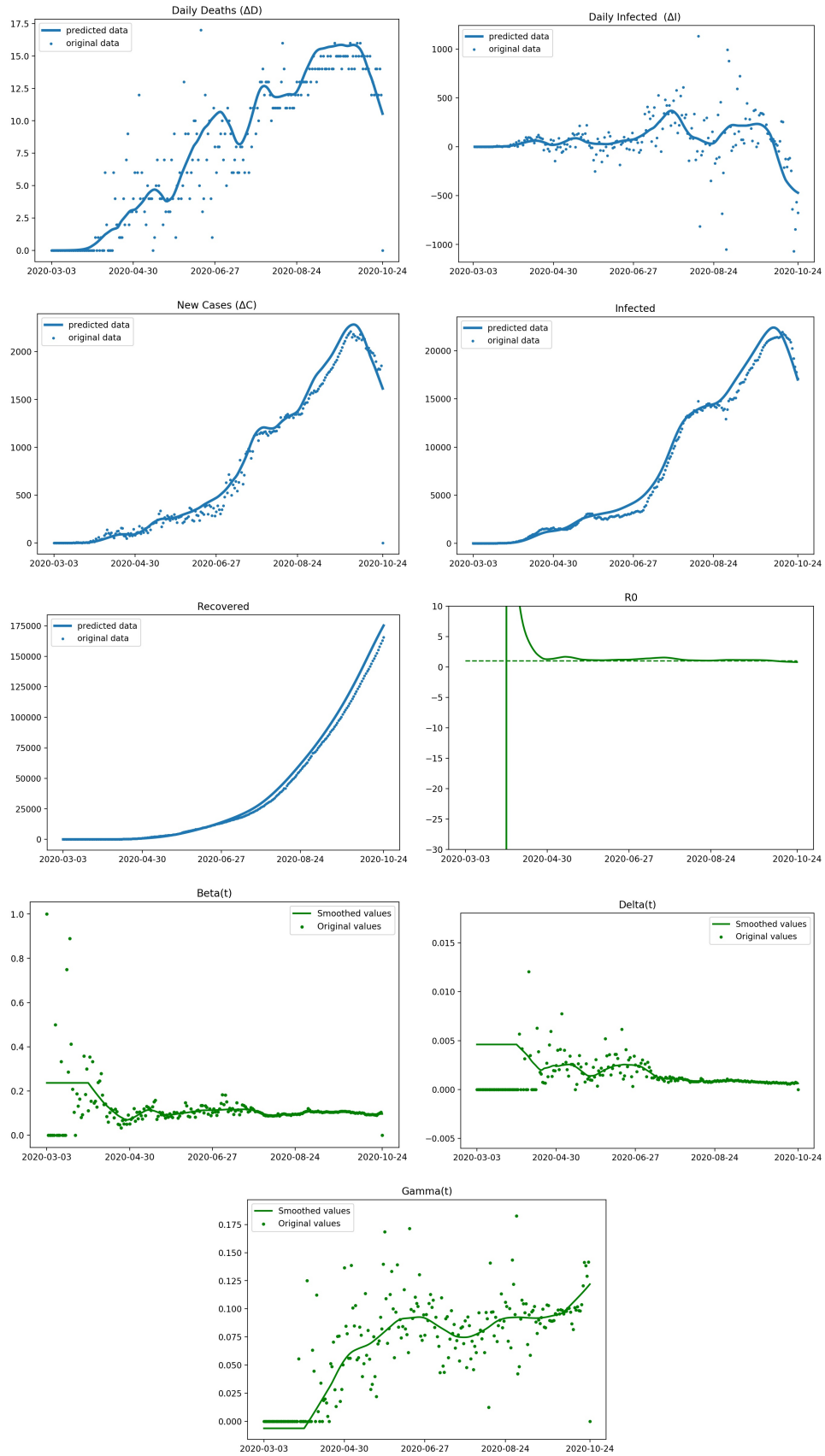

Fig. 14: Graphs of Rajasthan

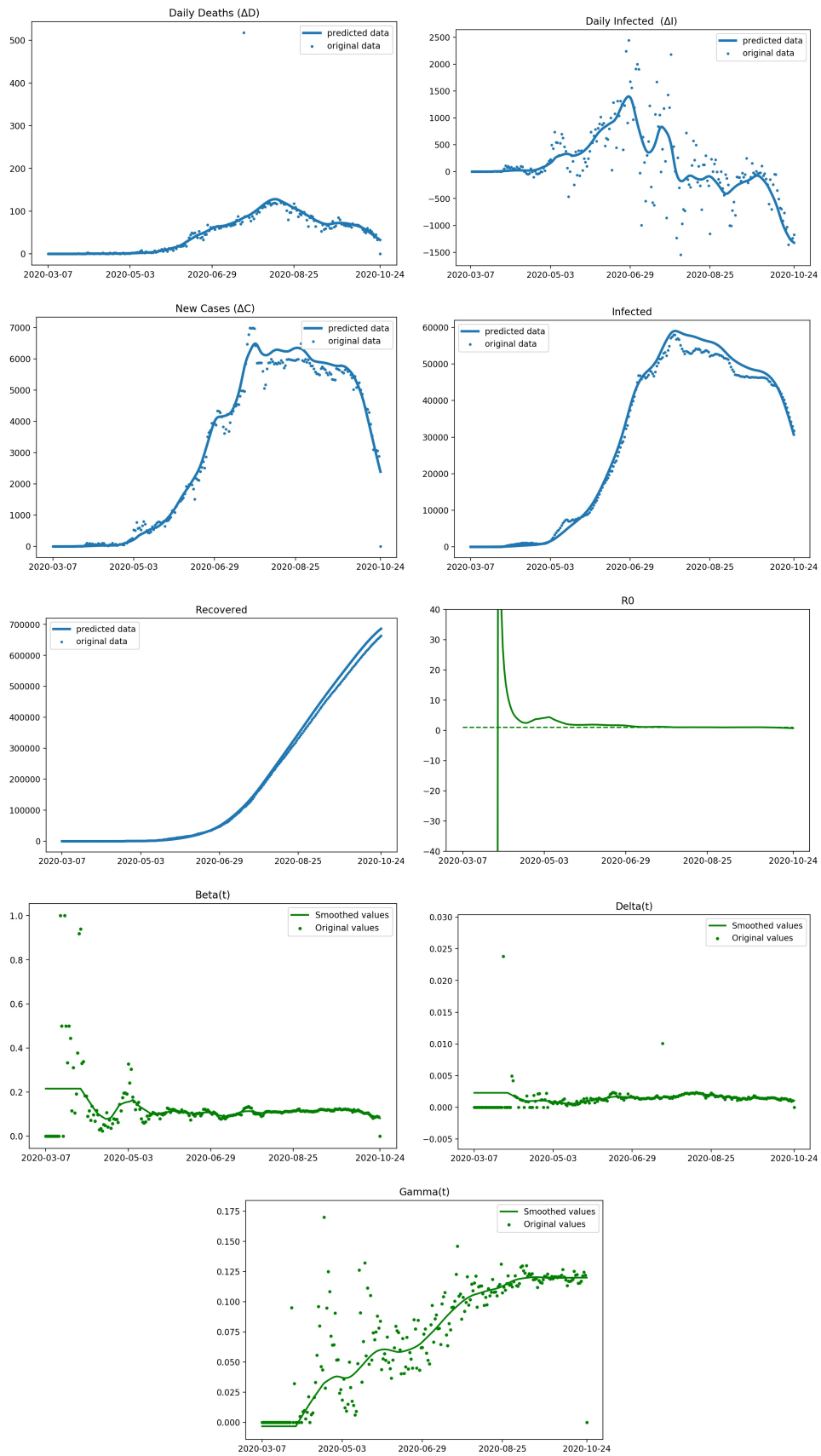

Fig. 15: Graphs of Tamil Nadu

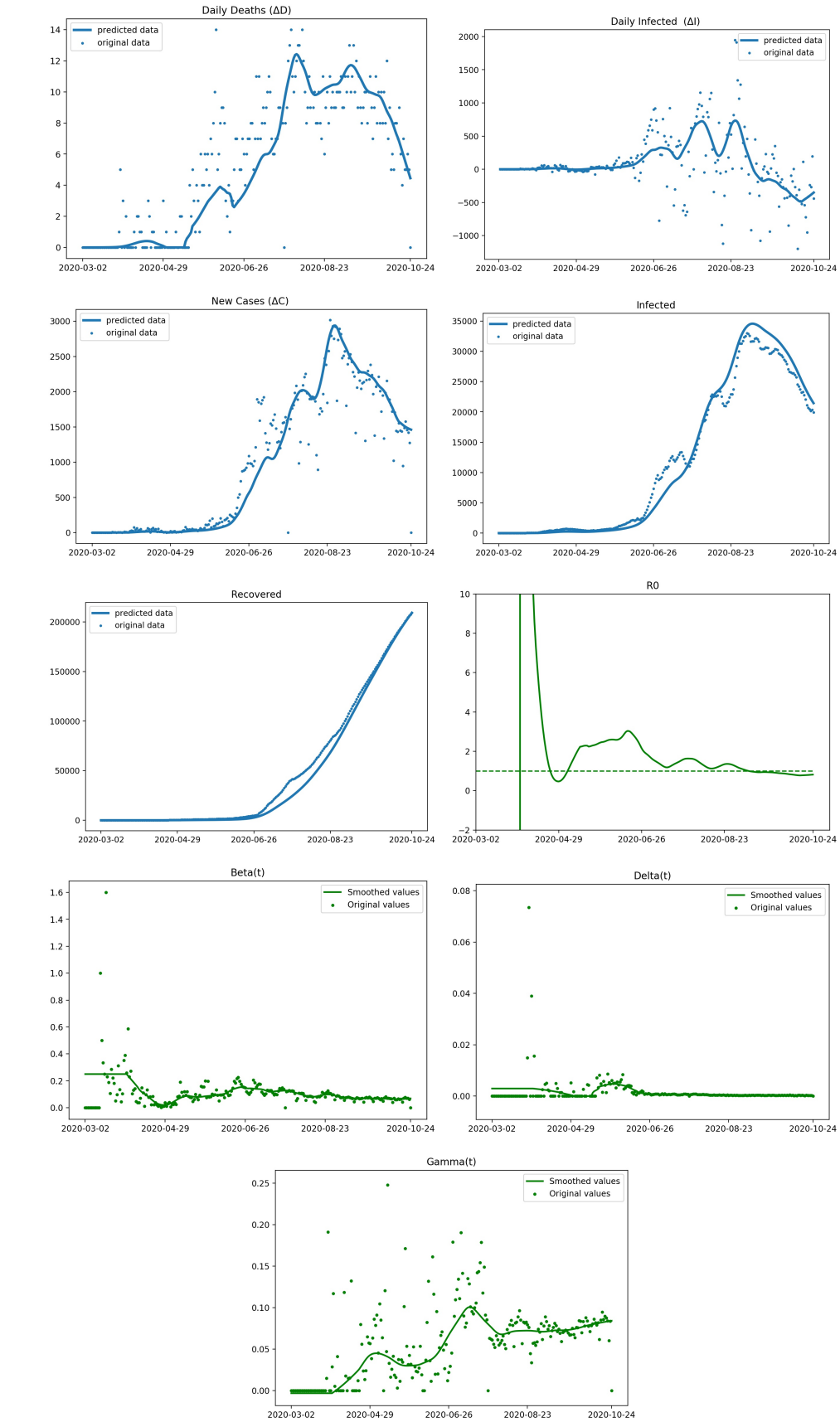

Fig. 16: Graphs of Telangana

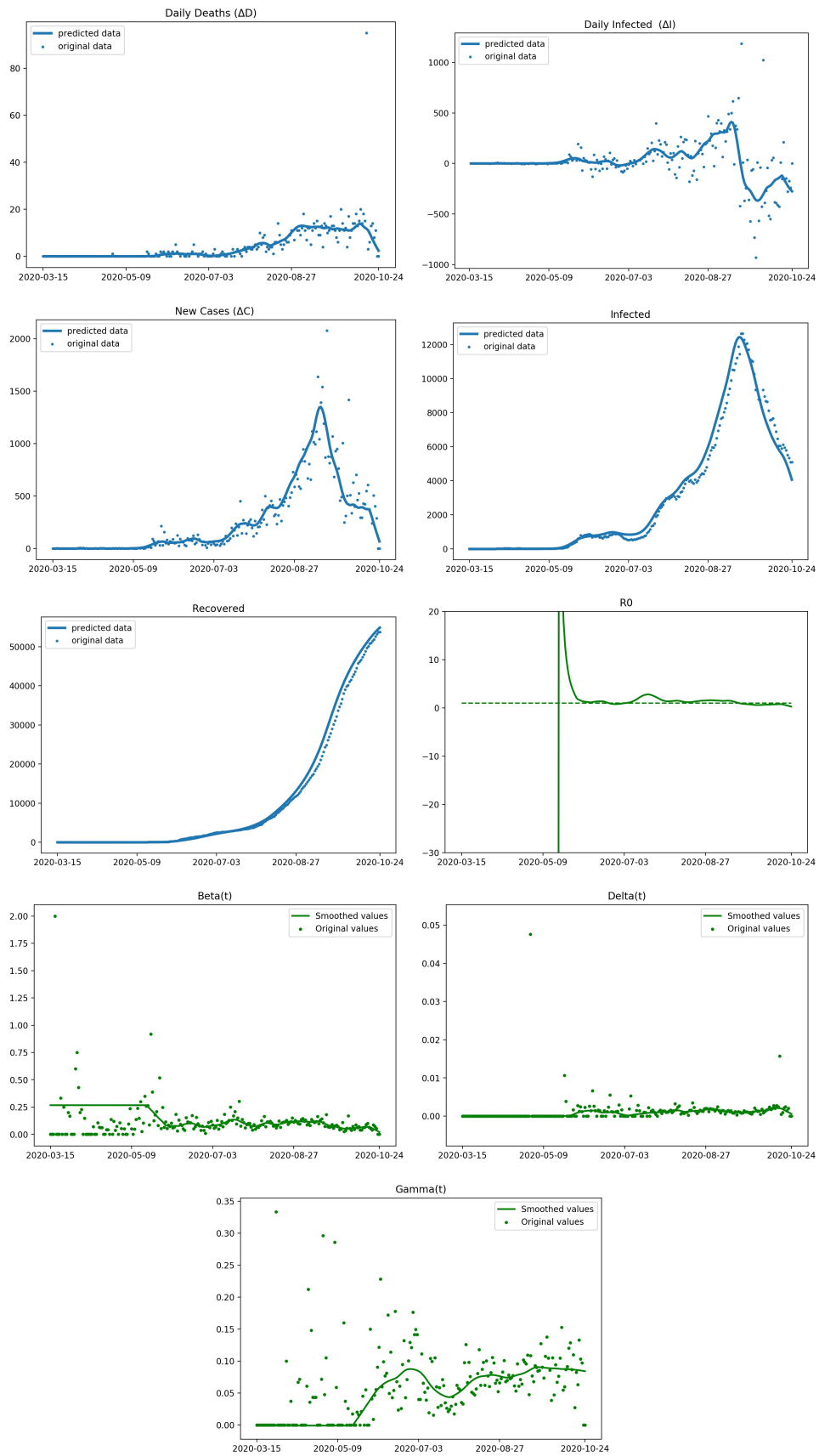

Fig. 17: Graphs of Uttarakhand

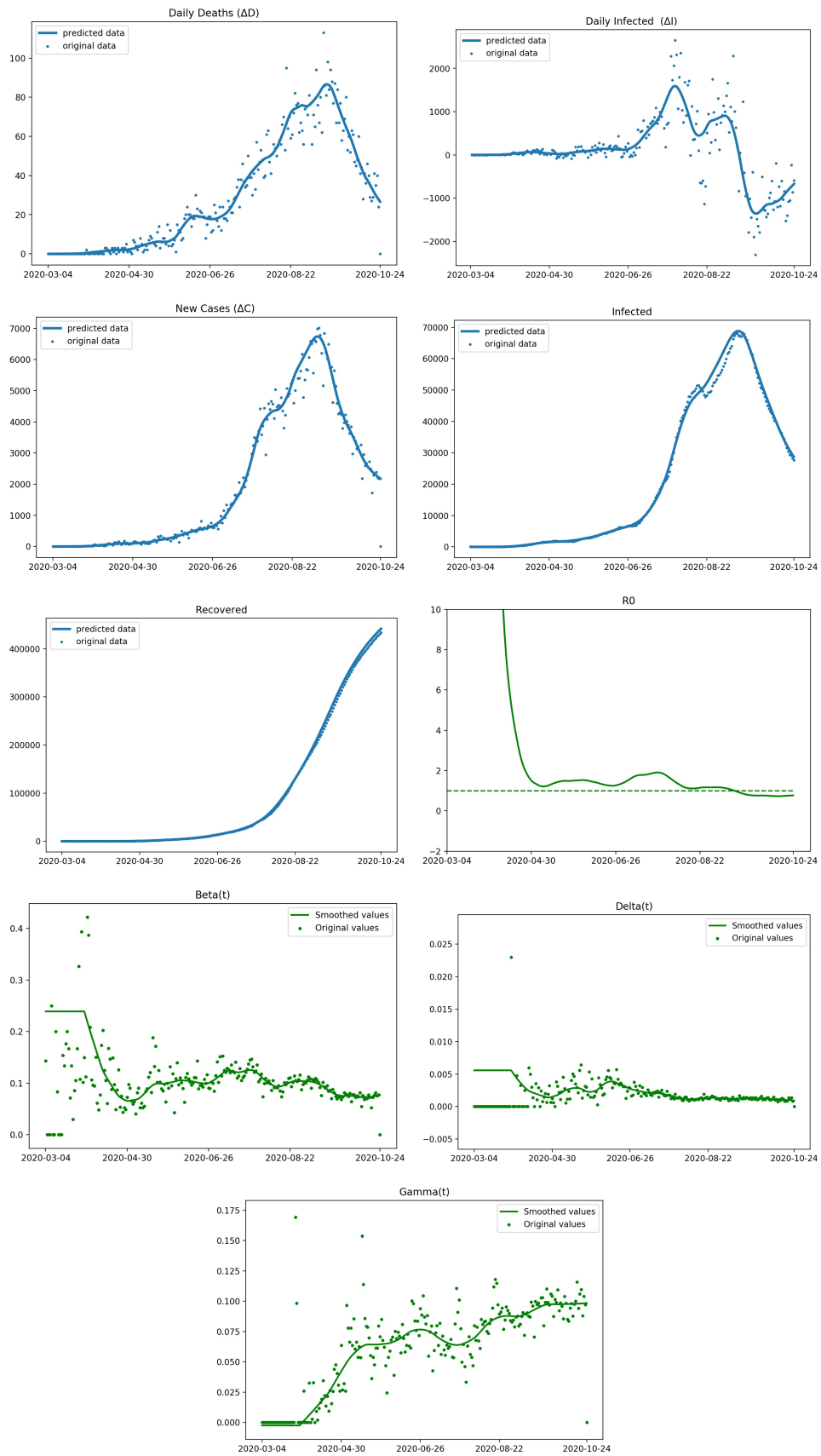

Fig. 18: Graphs of Uttar Pradesh

August with around 97 deaths on October 7, 2020. The highest number of new cases were observed in early September. The exponential growth parameter R_0 started to decline from first week of September, showing that the epidemic is under control in these states. The recovery rate is around 95%. The lockdown and unlock, along with masks use, social distancing and other preventive measures used by the government has relatively good effects in bringing the value of R_0 below 1 for these 14 States/UT with similar improving trends. The peaks attained by the above 14 States/UT in the number of daily new cases, infected (active) cases, and number of daily deaths can be observed from Table 4.

Table 4: Dates and Number of Cases for which peak values of ΔC , I and ΔD were attained

S. No.	State/UT Name	Daily New Cases (ΔC)	Infected (Active) (I)	Daily Deaths (ΔD)
1.	Andaman and Nicobar Islands	13/8/2020, 149 cases	15/8/2020, 1154 cases	25/8/2020, 5 cases
2.	Andhra Pradesh	25/8/2020, 10,830 cases	3/9/2020, 10,3701 cases	21/8/2020, 97 cases
3.	Chandigarh	12/9/2020, 449 cases	16/9/2020, 3174 cases	7/9/2020, 377 cases
4.	Himachal Pradesh	15/9/2020, 460 cases	21/9/2020, 4477 cases	18/9/2020, 12 cases
5.	Jammu and Kashmir	11/9/2020, 1698 cases	20/9/2020, 22,032 cases	20/9/2020, 23 cases
6.	Karnataka	12/9/2020, 9894 cases	9/10/2020, 1,18,870 cases	17/9/2020, 179 cases
7.	Ladakh	4/10/2020, 120 cases	8/10/2020, 1289 cases	23/9/2020, 3 cases
8.	Puducherry	23/9/2020, 668 cases	26/9/2020, 5327 cases	3/9/2020, 20 cases
9.	Punjab	16/9/2020, 2848 cases	19/9/2020, 22,399 cases	1/9/2020, 106 cases
10.	Rajasthan	30/9/2020, 2193 cases	13/10/2020, 21,924 cases	1/10/2020, 16 cases
11.	Tamil Nadu	26/7/2020, 6993 cases	31/7/2020, 57,968 cases	21/7/2020, 518 cases
12.	Telangana	2/8/2020, 3018 cases	4/9/2020, 32,994 cases	30/7/2020, 14 cases
13.	Uttarakhand	18/9/2020, 2078 cases	20/9/2020, 12,644 cases	16/10/2020, 95 cases
14.	Uttar Pradesh	10/9/2020, 7016 cases	17/9/2020, 68,235 cases	14/9/2020, 113 cases

The comparative analysis of actual value and predicted values of confirmed, recovered and deceased cases for all states/UT are discussed in Table 5.

Table 5: Comparative analysis of actual predicted values of confirmed, recovered, and deceased cases for all States/UT of Northern and Southern India

S.No.	Name of State/UT	Confirmed	Predicted Confirmed	Recovered	Predicted Recovered	Deceased	Predicted Deceased
1.	Andman and Nichobar Islands	4225	4413	3968	4131	58	52
2.	Andhra Pradesh	804026	789324	765991	748595	6566	6453
3.	Chandigarh	13977	14073	13087	13171	216	183
4.	Delhi	352520	368146	319828	322569	6225	4868
5.	Haryana	157064	155405	145196	143032	1720	1679
6.	Himachal Pradesh	20213	20667	17296	17445	285	271
7.	Jammu and Kashmir	91329	90724	82219	80052	1430	1379
8.	Karnataka	798378	778495	700737	682760	10873	10672
9.	Kerala	386088	395791	287261	295443	1307	1317
10.	Ladakh	5913	6506	5052	5412	71	36
11.	Puducherry	34112	32189	29614	28119	586	537
12.	Punjab	130640	129570	122256	120946	4107	4091
13.	Rajasthan	184422	194162	165496	175230	1826	1925
14.	Tamil Nadu	706136	727879	663456	686319	10893	10901
15.	Telangana	230274	231766	209034	209120	1303	1195
16.	Uttar Pradesh	468238	477439	433703	441822	6854	6195
17.	Uttarakhand	60155	60193	54169	55193	984	897

4 Conclusion

In this paper, a modified SIRD model is proposed to analyze the effect of different government interventions, implemented to reduce the spread of COVID-19 in Northern and Southern States/Union Territories of India. Depending upon the number of cases and growth rate of the epidemic, the states are categorized into three categories: states badly hit by Covid-19, states showing a second and third wave of new cases, and states showing similar trends. The smoothing function is used to reduce the process and measurement noise. The data from March 2, 2020, to October 24, 2020, is analyzed for near-future prediction. Through analysis, it is observed that the predicted values are nearby to the actual values and further, it is established that the states Kerala and Haryana were severely affected by Covid-19 whereas Delhi generated a second and third wave of new cases. The remaining states showed a moderate impact of COVID-19. The proposed SIRD model can further be enhanced to make predictions of weekly data by keeping the window size 7. The predictions achieved from the proposed model can be used by the national and states government authorities, researchers, and service managers to plan the medical infrastructure and other strategies in advance.

Acknowledgement

The work is supported by a joint collaborative project Design and Applications of Swarm Intelligence based algorithms for drone swarm and COVID19 Spread Prediction

References

1. Neeltje Van Doremalen, Trenton Bushmaker, Dylan H Morris, Myndi G Holbrook, Amandine Gamble, Brandi N Williamson, Azaibi Tamin, Jennifer L Harcourt, Natalie J Thornburg, Susan I Gerber, et al. Aerosol and surface stability of sars-cov-2 as compared with sars-cov-1. *New England Journal of Medicine*, 382(16):1564–1567, 2020.
2. Chaolin Huang, Yeming Wang, Xingwang Li, Lili Ren, Jianping Zhao, Yi Hu, Li Zhang, Guohui Fan, Jiuyang Xu, Xiaoying Gu, et al. Clinical features of patients infected with 2019 novel coronavirus in wuhan, china. *The lancet*, 395(10223):497–506, 2020.
3. Domenico Cucinotta and Maurizio Vanelli. Who declares covid-19 a pandemic. *Acta bio-medica: Atenei Parmensis*, 91(1):157–160, 2020.
4. John hopkins coronavirus resource centre. 2020 <https://coronavirus.jhu.edu/> (Accessed on 10/10/2020).
5. Mortality Analyses John hopkins coronavirus resource centre. 2020. <https://coronavirus.jhu.edu/data/mortality> (Accessed on 24/10/2020).
6. Roy M Anderson, Hans Heesterbeek, Don Klinkenberg, and T Déirdre Hollingsworth. How will country-based mitigation measures influence the course of the covid-19 epidemic? *The Lancet*, 395(10228):931–934, 2020.
7. Yun Qiu, Xi Chen, and Wei Shi. Impacts of social and economic factors on the transmission of coronavirus disease 2019 (covid-19) in china. *Journal of Population Economics*, page 1, 2020.
8. India Population (2020) worldometer. 2020. <https://www.worldometers.info/world-population/> (Accessed on 24/10/2020).
9. Cities by population density wikipedia. 2020. https://en.wikipedia.org/wiki/List_of_cities_proper_by_population (Accessed on 25/10/2020).
10. Angelo Carfi, Roberto Bernabei, Francesco Landi, et al. Persistent symptoms in patients after acute covid-19. *Jama*, 324(6):603–605, 2020.
11. Stephen A Lauer, Kyra H Grantz, Qifang Bi, Forrest K Jones, Qulu Zheng, Hannah R Meredith, Andrew S Azman, Nicholas G Reich, and Justin Lessler. The incubation period of coronavirus disease 2019 (covid-19) from publicly reported confirmed cases: estimation and application. *Annals of internal medicine*, 172(9):577–582, 2020.
12. Titan M Alon, Matthias Doepke, Jane Olmstead-Rumsey, and Michele Tertilt. The impact of covid-19 on gender equality. Technical report, National Bureau of Economic Research, 2020.
13. in line with WHO guidance COVID-19: Lockdown across India. March 24, 2020. <https://news.un.org/en/story/2020/03/1060132>, (Accessed on 25/10/2020).

14. India to remain closed till 3 May. Livemint, april 14, 2020. <https://www.livemint.com/news/india/pm-modi-announces-extension-of-lockdown-till-3-may-11586839412073.html>, (Accessed on 25/10/2020).
15. Lockdown for 2 more weeks starting 4th May. Ndtv.com. <https://www.ndtv.com/india-news/nationwide-lockdown-over-coronavirus-extended-for-two-weeks-beyond-may-4-2221782>, (Accessed on 25/10/2020).
16. Centre extends nationwide lockdown till May 31. The tribune india, october 17, 2020. <https://www.tribuneindia.com/news/nation/centre-extends-nationwide-lockdown-till-may-31-new-guidelines-issued-86042>, (Accessed on 25/10/2020).
17. Deepshikha (ed.). Sharma, Neeta (30 May 2020). Ghosh. "unlock1": Malls, restaurants, places of worship to reopen june 8". ndtv. retrieved 30 may 2020. (accessed on 25/10/2020).
18. Deeptiman (30 June 2020). Tiwary. "unlock 2: More flights, trains, but no schools and colleges till july 31". the indian express. retrieved 1 july 2020. (accessed on 25/10/2020).
19. what's not". The Indian Express. 30 July 2020. Retrieved 1 August 2020. "Unlock 3.0 guidelines: Here is what's allowed. (accessed on 25/10/2020).
20. The Indian Express. Retrieved 2 September 2020. "Unlock 4.0: Full guidelines issued by different states". (accessed on 25/10/2020).
21. social gatherings "Unlock 5.0 guidelines explained: What are the rules for schools and 2020. cinemas?" , The Indian Express. Retrieved 1 October. (accessed on 25/10/2020).
22. Press Information Bureau. *pib.gov.in*, (Accessed on 25/10/2020).
23. Simran Preet Kaur and Vandana Gupta. Covid-19 vaccine: A comprehensive status report. *Virus Research*, page 198114, 2020.
24. Abhijit Chakraborty, Jiaying Chen, Amelie Desvars-Larrive, Peter Klimek, Erwin Flores Tames, David Garcia, Leonhard Horstmeyer, Michaela Kaleta, Jana Lasser, Jenny Reddish, et al. Analyzing covid-19 data using sird models. *medRxiv*, 2020.
25. Stefano Merler, Marco Ajelli, Laura Fumanelli, Marcelo FC Gomes, Ana Pastore y Piontti, Luca Rossi, Dennis L Chao, Ira M Longini Jr, M Elizabeth Halloran, and Alessandro Vespignani. Spatiotemporal spread of the 2014 outbreak of ebola virus disease in liberia and the effectiveness of non-pharmaceutical interventions: a computational modelling analysis. *The Lancet Infectious Diseases*, 15(2):204–211, 2015.
26. Fred Brauer. Compartmental models in epidemiology. In *Mathematical epidemiology*, pages 19–79. Springer, 2008.
27. William Ogilvy Kermack and Anderson G McKendrick. A contribution to the mathematical theory of epidemics. *Proceedings of the royal society of london. Series A, Containing papers of a mathematical and physical character*, 115(772):700–721, 1927.
28. Tian-Mu Chen, Jia Rui, Qiu-Peng Wang, Ze-Yu Zhao, Jing-An Cui, and Ling Yin. A mathematical model for simulating the phase-based transmissibility of a novel coronavirus. *Infectious diseases of poverty*, 9(1):1–8, 2020.
29. Wei-min Liu, Simon A Levin, and Yoh Iwasa. Influence of nonlinear incidence rates upon the behavior of sirs epidemiological models. *Journal of mathematical biology*, 23(2):187–204, 1986.
30. Anwarud Din, Amir Khan, and Dumitru Baleanu. Stationary distribution and extinction of stochastic coronavirus (covid-19) epidemic model. *Chaos, Solitons & Fractals*, 139:110036, 2020.
31. Parvaiz Ahmad Naik, Mehmet Yavuz, Sania Qureshi, Jian Zu, and Stuart Townley. Modeling and analysis of covid-19 epidemics with treatment in fractional derivatives using real data from pakistan. *The European Physical Journal Plus*, 135(10):1–42, 2020.
32. Sania Qureshi and Abdon Atangana. Fractal-fractional differentiation for the modeling and mathematical analysis of nonlinear diarrhea transmission dynamics under the use of real data. *Chaos, Solitons & Fractals*, 136:109812, 2020.
33. Idris Ahmed, Goni Umar Modu, Abdullahi Yusuf, Poom Kumam, and Ibrahim Yusuf. A mathematical model of coronavirus disease (covid-19) containing asymptomatic and symptomatic classes. *Results in Physics*, page 103776, 2021.
34. Amin Jajarmi, Abdullahi Yusuf, Dumitru Baleanu, and Mustafa Inc. A new fractional hrsv model and its optimal control: a non-singular operator approach. *Physica A: Statistical Mechanics and its Applications*, 547:123860, 2020.
35. Nguyen Huy Tuan, Vo Viet Tri, and Dumitru Baleanu. Analysis of the fractional corona virus pandemic via deterministic modeling. *Mathematical Methods in the Applied Sciences*, 44(1):1086–1102, 2021.
36. Idris Ahmed, Isa Abdullahi Baba, Abdullahi Yusuf, Poom Kumam, and Wiyada Kumam. Analysis of caputo fractional-order model for covid-19 with lockdown. *Advances in Difference Equations*,

- 2020(1):1–14, 2020.
37. COVID 19 INDIA. Dataset. <https://www.covid19india.org/>, (Accessed on 24/10/2020).
 38. Elia Pintus, Silvia Sorbolini, Andrea Albera, Giustino Gaspa, Corrado Dimauro, Roberto Steri, Gabriele Marras, and Nicolo PP Macciotta. Use of locally weighted scatterplot smoothing (lowess) regression to study selection signatures in piedmontese and italian brown cattle breeds. *Animal Genetics*, 45(1):1–11, 2014.
 39. The Hindu. India's first coronavirus infection confirmed in kerala. <https://www.thehindu.com/news/national/indias-first-coronavirus-infection-confirmed-in-kerala/article30691004.ece>, 2020.