

# A LOW-COST PORTABLE HEALTH PLATFORM FOR THE MONITORING OF HUMAN PHYSIOLOGICAL SIGNALS

Keiran Brown\*, Emanuele Lindo Secco, Atulya Kumar Nagar

Robotics Laboratory, Department of Mathematics & Computer Science  
Liverpool Hope University, Hope Park, L16 9JD, Liverpool, UK  
{15000194, seccoe, nagara}@hope.ac.uk

**Abstract.** This work reports the integration and preliminary testing of a miniature commercial health platform based on the combination of a set of platforms that can be merged in hardware and software to measure and monitor many physiological parameters of the human body. The system is very portable, has a clear economic benefit in terms of cost and it has been well integrated with a customized and intuitive graphical user interface. Detailed about the materials used for preparation of this platform and the methods used for data collection are reported. Preliminary data has been collected and reported. Explanations are shown about the data in relation to the sensors behaviors and performance.

**Keywords:** Wearable Device, Low-cost Device, Monitoring of Physiological Parameters, Open Source Hardware and Software.

## 1 - Introduction

Low cost and wearable devices for the monitoring of physiological and environmental parameters have become more approachable due to the miniaturization of the electronics, the increasing performance of rechargeable battery and the development of wireless communication protocol. Such devices have a variety of application from the monitoring of health condition of elderly users to the life monitoring of soldier and emergency operators [1-2].

In this context some devices have been developed in the scientific community. Some notable developments are the Monitoring Camera [3], which monitors health conditions using visual information, it uses small changes in color of the skin, or slight changes in light reflection to infer parameters such as heart rate or body temperature. Another development is the eHealthGuard [4], which performs many individual elements where each one measures a specific aspect of a person's health and communicate using Bluetooth radios. Another similar development is the Fitbit [5]. This device is now a consumer product. It has a focus on physical activity of the person wearing it, it goes on the wrist and is able to measure various aspects of health. It uses an accelerometer to monitor walking & running activities as well as sleep activity to determine how well

---

the wearer is sleeping and what part of the sleep cycle they are in. The device uses an application to display various statistics about health and progress towards goals set by the user. It can also measure heart rate, altitude, ambient light and orientation relative to gravity and a digital compass. These sensors change with different versions (further details are available on [6]).

Pantelopoulos and Bourbakis presented a health monitoring system in 2010: this system performs the same task as the one of this work but using less expensive hardware and offloading tasks to existing hardware [7]. This paper outlines a design for a system that takes the raw signals from the various sensors and performs the electronic processes that convert the analogue signals into digital signals. Then the processing that would typically be done by the E-Health board is done by a wearer's smartphone. Smartphones are an already very common technology throughout the general population and even if the wearer doesn't have one, providing one would cost much less than an E-Health board.

Another similar development is presented in [8]: it is very similar to the aforementioned one, but it actually uses the E-Health board to perform the signal processing from the sensors themselves. The signals are still sent to a smart phone however, this seems to be the best solution for most health monitoring solutions as this is a computer that can gather data and send them to the cloud where they may be stored on servers [8].

Both of these solutions use XBee communication modules (IEEE 802.15.4) to transfer their data wirelessly to the reading device. This will be due to the low cost, low-power consumption and ease of use of XBee modules.

Finally, another development using again, independent sensors is a proposed system for ubiquitous health monitoring using a wireless body sensor network [9]. This connects to the internet to communicate various health related parameters. There is an emphasis on making the sensors very small to minimize effect on everyday life for the wearer. Although, noted, are the challenges faced with accuracy and precision of such sensors when performing miniaturization.

In this paper we propose an integrated low-cost platform for the low-cost and wearable monitoring of physiological parameters: the platform is based on a commercial hardware solution combined with a wireless communication protocol and a customized visualization software (Figure 1). This development is important as it could be a solution for monitoring health parameters of patients both inside and outside of treatment facilities enabling health issues to be realized earlier than if only checkups were utilized.

The paper is organized in four main parts concerning the hardware and software components (Par. 2), their functional integration (Par. 3) and some preliminary results (Par. 4). Further two parts report the final discussion and conclusion (Par. 5 & 6, respectively).

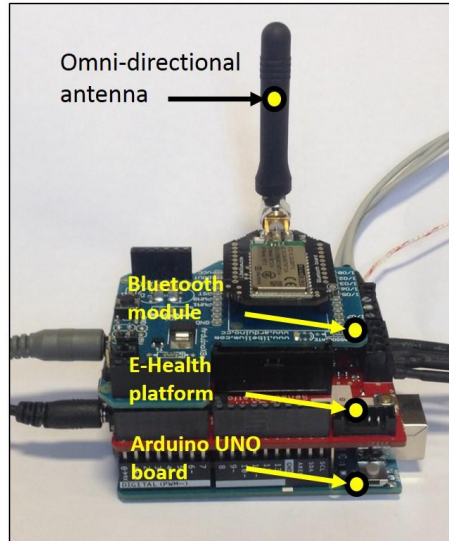

**Fig. 1.** Overall Hardware Design.

## **2 - Materials: Hardware and Software**

This section is broken down into the description of the HardWare (HW) and SoftWare (SW) components of the proposed architecture. A further part details the implemented Graphical User Interface (GUI) for the project, allowing for its function directly.

### **2.1 - Hardware**

All the Hardware components which have been used for this architecture are detailed in this paragraph.

#### **2.1.1. - Arduino Uno Board**

Arduino is a low-cost open source platform. The board task is to perform data collection and transformation of data for serial transfer to a computer capable of extracting and displaying individual data points. It does this using a microcontroller which is situated on a small printed circuit board that has many components enabling the microcontroller to function as, for example, a linear voltage regulator that fixes the incoming voltage to 5V DC to ensure no damage of the components.

### 2.1.2. - E-Health Board

The E-Health board is a commercial device, which can read, sample and measure all the signals of a set of physiological sensors and then send these information to the Arduino Uno board for their collection [10]. The board, in the proposed set-up, costs less than 500 Euro and allows the monitoring of multiple physiological parameter. Current portable device for monitoring just one parameter, i.e. the ECG signal for example, can cost the same amount of money [11]. The board contains a processor that is designed to read incoming Analogue and Digital signals from the various medical sensors. This board is used as an easy way of gathering the information from all of these sensors and outputting their respective signals to be made use of. In a future development, this may be used as a custom integrated solution with lower cost and improve performance.

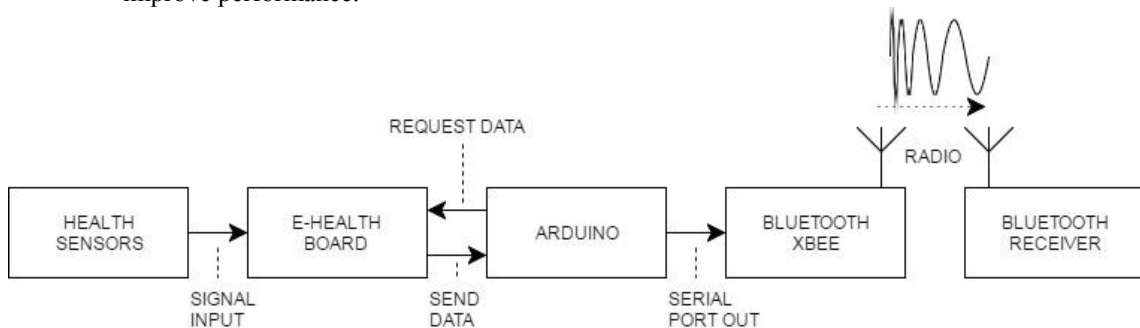

Fig. 2. Overall Design of Framework (J Graph, 2017).

### 2.1.3. - E-Health Transducers

The E-Health sensors are able to measure various stimulus determining the state of various parameters of the human body. Each sensor is unique, some of them contain some local processing features for collecting information and digitizing it, some are simply passive transducers that modulate the electrical signals in proportion to the outside stimulus.

#### a. Temperature Sensor

This sensor measures the temperature of the body using a resistive element, namely a Thermistor, which has a resistance that is proportional to the temperature. The Thermistor consists of a material in which the electrical resistance grows with temperature, this limits the current flowing through it, although if the current is kept constant the changing voltage, which rises with resistance, can be measured to determine the temperature.

#### b. Pulse Oximeter

This sensor uses two LEDs, one infrared and one red to detect the oxygenation of Haemoglobin in the bloodstream to determine the oxygenation of the blood. It also

detects the Heart Rate by using the expansion and contraction rates of blood vessels in the fingertip.

*c. ElectroCardioGram (ECG) & ElectroMyoGraphy (EMG) Electrodes*

Both ECG and EMG signals require the same physical interface, which measures the potential differences between three superficial electrodes to be applied on the subject's skin. The ECG detects this information across the heart muscles to determine the change in electrical signals across the heart. This determines the health of heart muscles, as the higher signal strengths tends to mean healthier muscles. The same sensor can be used elsewhere on the body in order to detect the muscle activity, namely the EMG: this measures the electrical signals across other muscles such as in the arm, but infers information about the health of motor neurons controlling those muscles, which can become weak because of some subject physical impairments.

*d. Glucometer*

This sensor uses a small strip that collects a small amount of blood to measure blood sugar levels. This strip is inserted into a Glucometer, which has electrodes that - when they encounter the Glucose in the blood - they react, producing a small electric current [12]. This current can be measured: the more intense the current is, the more Glucose concentration is present in the subjects' blood sample.

*e. Galvanic Skin Response*

This sensor is a constant current sensor which is able to measure the resistance between two points by producing a voltage performing a constant current source. The resistance can then be calculated using this reading. This sensor shows the conductivity of skin, which rises as a person sweats due to stress.

*f. Breathing Rate Sensor*

This further device uses a thermocouple to measure the change in the temperature of the air around two probes which have to be inserted on the nose of the subject. This only detects the warmer air from outward breaths. The higher the outward breathing rate, the higher the temperature reaches at the probes and thus, a higher reading is detected.

*g. Bluetooth & X-Bee Wireless Communication Board*

This board is mounted on top of the E-Health shield (Figure 1) and it collects the serial data from the Arduino Uno, buffer them temporarily, and then - after encrypting them - it sends those data via a modulated radio signal to the a Bluetooth dongle receiver (i.e. the IEEE 802.11 communication protocol).

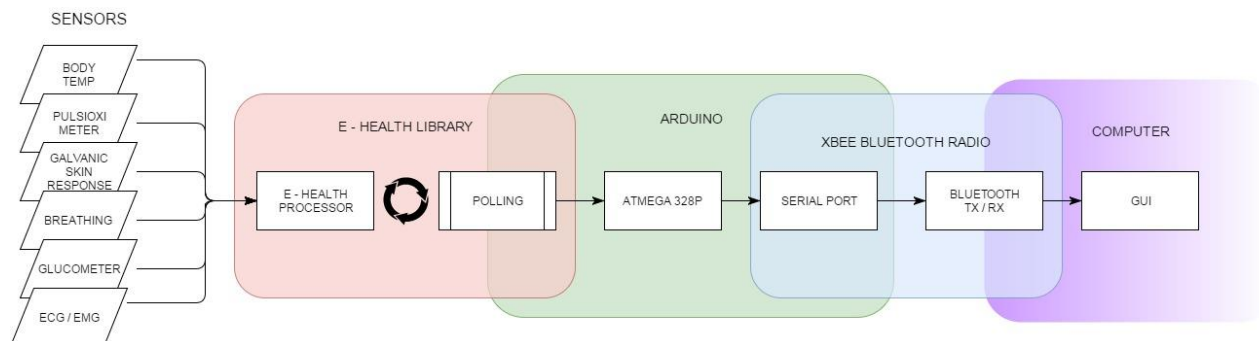

**Fig. 3.** Flowchart Showing Software Processes.

#### *h. Power Supply*

The power supply package is set-up in order to contain 8 AA batteries providing a 12V DC: it is soldered to a DC jack for supplying such power to the Arduino board, which will cut down the voltage to 5V DC by means of the aforementioned linear voltage regulator.

---

Figure 2 shows how the hardware interfaces together. Each arrow represents a process between two different parts of the system. The general flow of information is from the left to the right since the sensor information are modulated into the radio signal which is received by the Bluetooth dongle.

## **2.2 - Software**

All the Software components are detailed in this paragraph. In particular, Figure 3 shows the processes involved in the Software. The figure also displays how the different parts are linked together through the Software: for instance, an E-Health Library allows linking the E-Health hardware to the Arduino board by giving access to the sensors' reading; this process is controlled through the polling of each sensor indirectly by the Arduino microcontroller (i.e. the ATmega 328P - [13]).

### **2.2.1. - Arduino Code**

This comes in the form of a piece of C code that is uploaded to the Arduino board: it allows controlling how the board micro-controller collects and processes the sensors' data. This doesn't require any outside software, only ASCII is used to interface different modules together (Arduino – [14]).

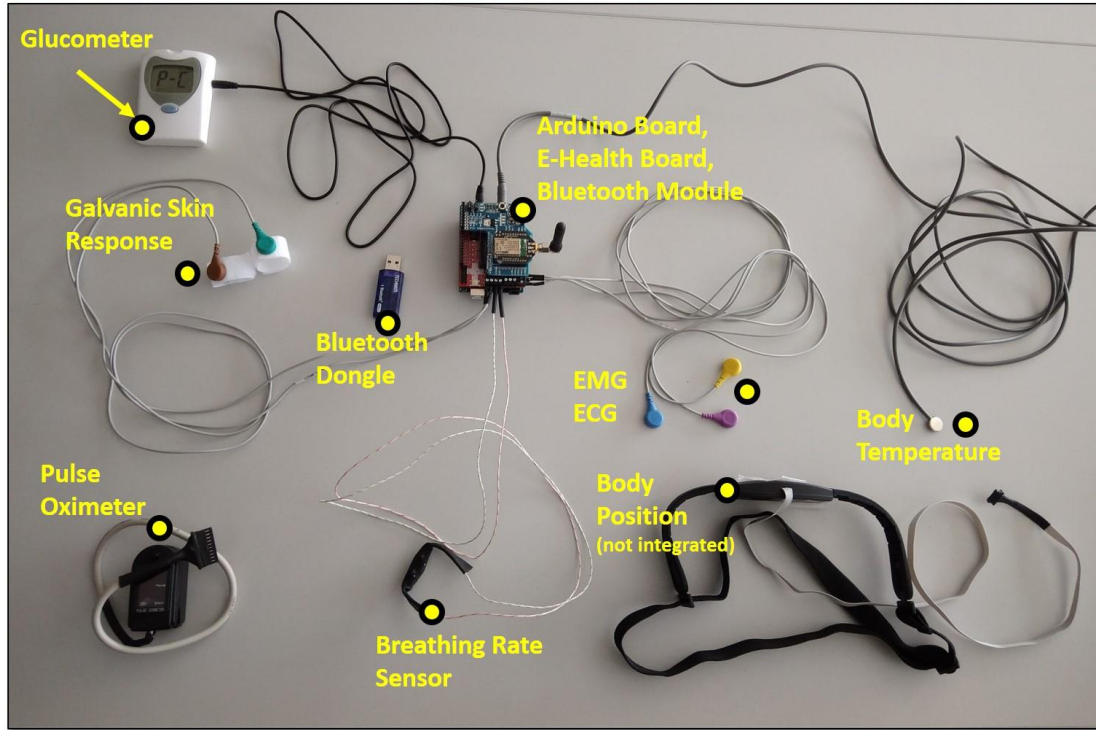

**Fig. 4.** Overall components and set of sensors.

### 2.2.2. Java Code

A Java software-based program is used on a remote computer integrating the Bluetooth dongle, which display the information in a more readable fashion: the GUI is developed by using the Processing Development Environment (PDE). This leads to a flexible application that can be executed on any device as long as it has Java installed, which is a very commonplace software [15, 16].

### 2.2.3. Bluetooth Wireless communication Module

The Bluetooth module is controlled by using the serial port of the Bluetooth module itself and sending ASCII commands to set-up the password, ask for acknowledgements, and so on. This gives flexibility to the module as well.

### 2.2.4. Integration

Figure 4 and 1 show all the components of the integrated device, namely (i) the platform with the Bluetooth X-Bee board, which slots into the top of the E-Health board and (ii) the integrated boards, respectively.

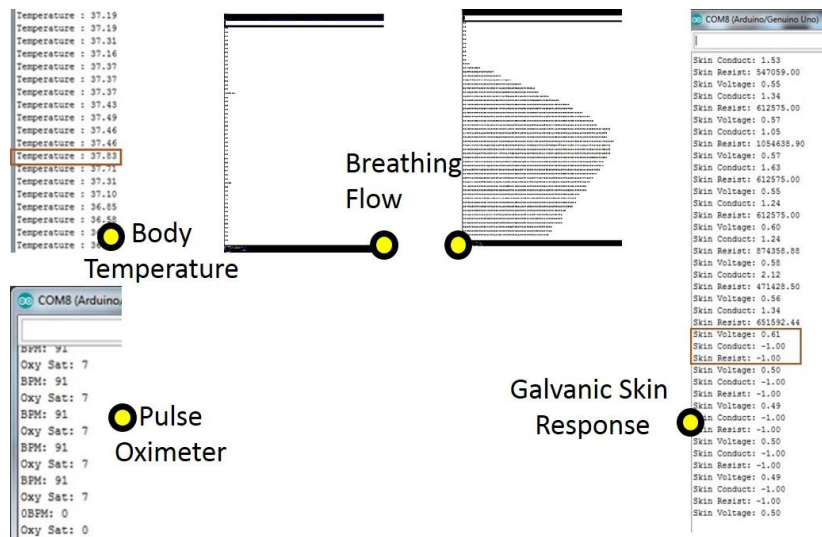

Fig. 5. Raw output of the sensor set.

### 3 - Functional Integration

This is the functional approach of the developed system: the aforementioned sensors convert the energy from the external and physiological stimulus to electrical signals by using various methods. These signals are appropriately gathered by the E-Health board. Then, the Arduino board interrogates the E-Health board for each of the latest taken readings by using the E-Health Board Library (Figure 3). Once all sensorial information have been obtained, data in its raw form are concatenated together into a single long string with semicolon markers in order to delimit each information. The string is then sent down to the Arduino serial port, which connects to the Bluetooth module buffering these data and sending them via the modulated radio waves to the receiver who has been initially paired and authorized (Figure 2). The Arduino is sending information down a Serial Port and data are packaged with a marker - the word “ARDUINO” is used at the beginning as a one-way handshake - enabling the software at the receiver to correctly identify the source. The receiver can then split the string of data, remove the semicolons and read each data as a floating point number which refer to a specific sensor, according to his position. Finally the data are then displayed on the screen of the computer via the developed GUI (Figure 5).

### 4 - Testing

This Section reports the data that has been gathered by the device. These readings can be displayed in their raw form, before being used within the GUI. These results are



gathered by using the sensors on a wearer. No gold standard equipment or certified medical equipment were used during these preliminary testing. Readings were taken to verify that sensors are properly functioning and that their signals are robust vs noise and movement artefacts.

In the future when hardware will be modified, tests will be performed to verify that these sensors function well compared to verified medical equipment [2]. This would properly validate their readings and ensure accuracy [17-19].

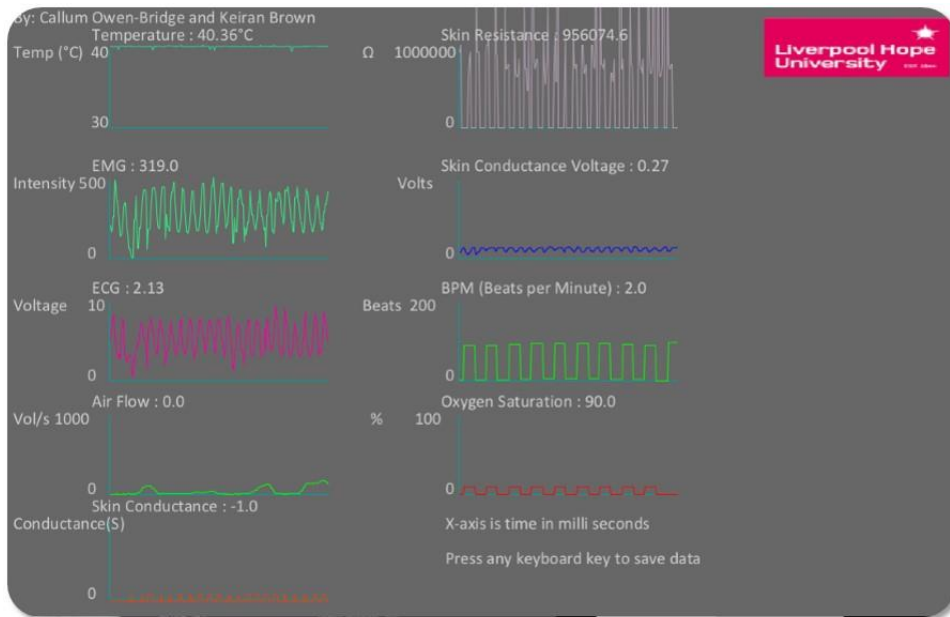

**Fig. 6.** The friendly and customized Graphical User Interface (GUI) Software.

#### 4.1 - Airflow

Figures 5 displays idle and breathing sensor readings, respectively as well as the other sensor output. As it can be observed from the graphs, a small amount of noise can be noticed, although it is quite small compared to the actual reading, which is clear.

According to the output, the measured airflow is an absolute data and not a rate of the airflow (i.e. the subject's breathing rate): this latter one can be determined by using a differential of the absolute reading. Similar information can be displayed for the other sensor.

## 4.2 - Temperature

The raw output of the temperature sensor is also shown in Figure 5: the figure reports a set of temperature readings, where the idle reading is around 35 °C, since the typical sensor range is tailored to measure the human body temperature. The highlighted temperature reading in Figure 5 shows when the sensor was taken away from the body of the subject and left open to the air again, at which point the temperature began to fall again. Each reading was performed every half a second, to give an indication of the time frame for readings of this sensor

## 4.3 - Pulse Oximeter

This sensor returns two output: the heart rate and the oxygenation of the blood. Figure 5 shows these readings on the bottom left panel, the last reading shows that when the sensor is removed from the body, then the sensor is returning a proper zero value. Oxygen saturation readings only show a single integer, here it reports a value of 7 which infers 97% blood Oxygen saturation. The readings were quite consistent and show little error.

**Table 1.** - Average, Standard Deviation and - if applicable - the Mean Rate of Change of Sensor Readings.

Sensor	Number of Readings	Average	Standard Deviation	Mean Rate of Change
Body Temperature (Warming) [°C]	25	36.81	0.736	0.194 °C s <sup>-1</sup>
Body Temperature (Cooling) [°C]	19	35.698	1.230	-1.230 °C s <sup>-1</sup>
Skin Conductance [S]	8	1.436	0.3079	-
Skin Resistance [Ω]	7	689175	188458	-
Skin Conductance Voltage [V]	7	0.569	0.016	-
Heart Rate [bpm]	6	75.833	33.914	-
Blood Oxygenation [% O <sub>2</sub> ]	6	80.833	36.150	-

°C stands for Celsius degrees; S stands for skin conductance; Ω stands for Ohm; V stands for Voltage; bpm stands for beats per minute and % O<sub>2</sub> stands for the percentage of Oxygen in blood

#### **4.4 - Galvanic Skin Response (GSR)**

The readings for Galvanic Skin Response are shown in Figure 5, left panel. The highlighted reading shows when the transducer was removed from the body as well: this sensor produced a small voltage which is being produced to attempt to retain the constant current source, whilst other readings are far out of range and so a value of *-1.00* is displayed as a default.

#### **4.5 - Glucometer**

The readings for the Glucometer were taken on a separated module and then the E-Health board was performing the reading to be passed on to the Arduino board. The Glucometer sensor also has a built-in memory, such as the taken sensor readings may be read as long as they are stored.

In order to report an overall data acquisition, Table 1 shows the average of each sensor reading. It also shows the Standard Deviation of each reading, according to a preliminary set of trials, which have been performed.

Figure 6 shows the Java application, which was developed in order to practically visualise the values and the time pattern of the values of each sensors in real-time. This interface was develop din order to make the data more acceptable from end-users with no expertise vs. physiological and medical parameters.

The software is combined with a one-way handshake in order to manage the wireless communication. All data are displayed graphically for ease of use. This provides a level of abstraction for any user, as they may use all components and wirelessly transfer data to a computer without knowledge of the intermediate components.

According to the organisation and implementation of this GUI, the end-user only needs to know how to apply the sensors and how to read the data.

### **5 - Discussion**

This platform provides some reliable operation for a relatively low cost compared to the typical medical equipment seen in hospitals. It is an example of how miniaturization can be achieved with current technology. If medically certified, this would provide a platform for easily measuring many details of a person's health which was before only possible at a hospital, with much more expensive equipment.

As for the hardware reliability, vulnerabilities only lie in the sensors themselves. The E-Health board is very accurate and able to take very fast readings and buffer them. The Arduino Uno is very capable at gathering and sending out data. A one-way handshake has been implemented using the Arduino with Bluetooth Security on top, allowing for a receiving machine to listen for the Arduino. Due to the nature of this one-way handshake, the Arduino can be disconnected and reconnected without having to restart the receiving application.

In order to consolidate these results and optimize the software and hardware, further experiments should be performed to test and validate the system in a real scenario. These tests should also verify the performance of the system vs the movement artefacts, which typically occur on wearable applications for Daily Life Activity of the subject.

## **6 - Conclusion**

The development process for this device involved working out how to get various platforms to work together as well as working with software. This prompted some work on how the E-Health board works and how sensors work with that board. This helped with gathering information by the Arduino, which must not make assumptions or errors in readings so the correct polling rate was necessary and the Arduino must wait for the sensors if readings are not yet available. Interfacing with the wireless communication module (i.e. the Bluetooth communication protocol) using the Arduino involved inserting a level of abstraction between the platforms. As it has been reported in Par. 3, the Arduino was sending information down a Serial Port and was not aware of the Bluetooth communication shield: therefore, the data has to be packaged with a marker (i.e. one-way handshake) enabling the software at the receiver to correctly identify the source. The wireless module was only concerned with taking any received bytes and packing them into packets for Bluetooth encryption/transmission.

The proposed platform is quite small and all the sensors are removable and will not affect operation if not present (should the user only want to use a subset of the sensors). Such type of systems can be used for different purposes, due to their probability [17-19]. The completed platform is able to measure every sensor with proper accuracy. This is done at a reasonable rate, considering that all readings can be taken within 2 seconds. This can vary depending on some sensors, for instance, the Pulse Oximeter does some independent processing and storage of the readings and so, if there are more readings stored than usual, the Arduino can take a little longer to detect, which is the last updated reading.

## **7 - Future Developments**

This project could be modified to reduce the cost and improve accuracy, and possibly, increase its usefulness in patient monitoring and diagnosis. To reduce costs, the E-Health board could be replaced with a board containing amplifiers, filters and Analogue to Digital Converters (ADC) necessary to read the signals using the Arduino platform,

this would reduce cost and processing could be done with either a smartphone or a small processor. This may eliminate the need for an Arduino also as depending on the processor used, it may be able to read inputs from sensors. A better processor of the information from the sensors may also improve the accuracy of the device and enable it to take in information at a faster rate, for instance, by having more control over the Pulsioximeter hardware the polling rate would be increased as the system would not have to wait for it to finish reading as it has to now.

Another possible development is the integration of this monitor with advisory software or Artificial Intelligence [20]. By having a suite of health parameters about a person, intelligent software may be able to advise the wearer on actions to take to improve their health or to visit their doctor, software may also be able to spot what a doctor has missed.

**Acknowledgments.** We thank you all staff of the Department of Mathematics and Computer Science for their valuable support and in particular: Mr. M. Barrett-Baxendale & Prof. D. Reid, Ms J. Burnett & Miss S. Benson.

This work was presented in report form in fulfilment of the requirements for the course in Electronic Engineering for the student K. Brown under the supervision of E.L. Secco from the [Robotics Laboratory, Department of Mathematics & Computer Science, Liverpool Hope University.](#)

## References

1. Magenes, G., Curone, D., Secco E.L., Bonfiglio A.: The ProeTEX prototype: a wearable integrated system for physiological & environmental monitoring of emergency operators, 1st IEEE EMBS Unconference on Wearable & Ubiquitous Technology for Health & Wellness, Boston 2011
2. Curone, D., Secco, E.L., Caldani, L., Lanatà, A., Paradiso, R., Tognetti, A., Magenes, G.: Assessment of Sensing Fire Fighters Uniforms for Physiological parameter Measurement in Harsh Environment, *IEEE Trans on Information Technology in Biomedicine*, 16(3), 501-511 (2012)
3. Oxehealth, Technology - Oxehealth". Oxehealth (2017)
4. Fan, H., Xaiobin, L., Qian, Z.: Ehealthguard: A Personal Mobile Health Monitoring Platform. Institute for Computer Sciences, Social-Informatics and Telecommunications Engineering (ICST), 122-123 (2011)
5. Diaz, K.M., Krupka, D.J., Chang, M.J., Peacock, J., Ma, Y., Goldsmith, J., Schwartz, J.E., Davidson, K.W.: Fitbit®: An accurate and reliable device for wireless physical activity tracking. In: *International Journal of Cardiology*, 185:138-40 (2015)
6. FitBit Inc Corp. website: [www.fitbit.com](http://www.fitbit.com)
7. A. Pantelopoulos and N. G. Bourbakis, "A Survey on Wearable Sensor-Based Systems for Health Monitoring and Prognosis," in *IEEE Transactions on Systems, Man, and Cybernetics, Part C (Applications and Reviews)*, vol. 40, no. 1, pp. 1-12, Jan. 2010.
8. R. M. D. Omer and N. K. Al-Salihi, "HealthMate: Smart Wearable System for Health Monitoring (SWSHM)," *2017 IEEE 14th International Conference on Networking, Sensing and Control (ICNSC)*, Calabria, Italy, 2017, pp. 755-760.
9. Otto, C., Milenkovic, A., Sanders, C. and Jovanov, E.: System architecture of a wireless body area sensor network for ubiquitous health monitoring. *Journal of Mobile Multimedia*, 1(4), 307-326 (2006)
10. Cooking Hacks website: <https://www.cooking-hacks.com>
11. Spacelabs Cardiocall VS20 DualMode ECG Event Recorder: <https://www.medisave.co.uk/spacelabs-cardiocall-ecg-recorder.html>
12. Garcia, Y.M.: *Glucose Meter Fundamentals And Design*. 1<sup>st</sup> ed. Freescale Semiconductor, Inc. (2017)
13. Atmel Corp. website: [www.atmel.com](http://www.atmel.com)
14. Arduino cc: <https://www.arduino.cc/en/Main/AboutUs>
15. Reas, C., Ben F.: *Processing: A Programming Handbook for Visual Designers and Artists*, Second Edition (2017)
16. Bateman, G.: *Processing/processing* GitHub, <https://github.com/processing/processing/tree/master/java/libraries/serial> - (2017)
17. Magenes, G., Curone, D., Secco, E.L., Bonfiglio, A.: The ProeTEX prototype: a wearable integrated system for physiological & environmental monitoring of emergency operators, 1st - IEEE EMBS Unconference on Wearable & Ubiquitous Technology for Health & Wellness, Boston (2011)
18. Secco, E.L., Curone, D., Tognetti, A., Bonfiglio, A., Magenes, G.: Validation of Smart Garments for Physiological and Activity-Related Monitoring of Humans in Harsh Environment, *American Journal of Biomedical Engineering*, 2(4), 189-196 (2012)
19. Curone, D., Secco, E.L., Tognetti A., Magenes, G.: An Activity Classifier based on Heart rate and Accelerometer Data Fusion, 7<sup>th</sup> International Workshop on Biosignal Interpretation, 169-172, Italy (2012)
20. A. S. Mahajan, R. Y. Pattar, R. Khamitkar, M. Akalawadi and K. Bhat, "Doctor's innovative clinic: An application of artificial intelligence and physiological sensors," *2016 International Conference on Advances in Human Machine Interaction (HMI)*, Doddaballapur, 2016, pp. 1-5.